

*S.16 Planning Application for Proposed Temporary Warehouse (Excluding Dangerous Goods Godown) with Ancillary Facilities and Associated Filling of Land for a Period of 3 Years in "Agriculture" Zone, Lots 1212 (Part), 1213, 1214, 1215, 1216, 1447 (Part), 1448 (Part), 1477 S.A (Part), 1478 RP (Part) in D.D. 106 and adjoining Government Land, Kam Tin, Yuen Long, New Territories*

*Planning Statement*

---

## **Appendix A**

### **Details of Affected Business**

Details of the Affected Business affected by Second Phase Development of the Hung Shui Kiu / Ha Tseun New Development Area

Name of Affected Kwok Kai Wing

Business Operator:

Location: Lots 4 (Part), 5 (Part), 6 (Part), 7 S.A (Part), 7 S.B (Part), 7 RP (Part), 8, 9 RP, 10, 11, 42 (Part), 43 (Part), 44 (Part), 45 (Part), 46 S.A (Part), 46 S.B (Part), 46 RP, 47 (Part), 57 (Part) and 58 (Part) in D.D. 124 and Lots 1498 S.A ss.2, 1498 S.B RP (Part), 1529 RP (Part) and 1556 S.B (Part) in D.D. 125, Ha Tsuen, Yuen Long, New Territories

Subject OZP: Draft Hung Shui Kiu and Ha Tsuen OZP No. S/HSK/3

Zoning: "Open Space" ("O"), "Other Specified Uses" annotated "Logistics Facility" and area shown as "Road"

Site Area: 17,170m<sup>2</sup> (about)

Use: Warehouse (Storage of miscellaneous goods e.g. construction materials, construction machineries and vehicle parts etc.)

Extract of subject OZP

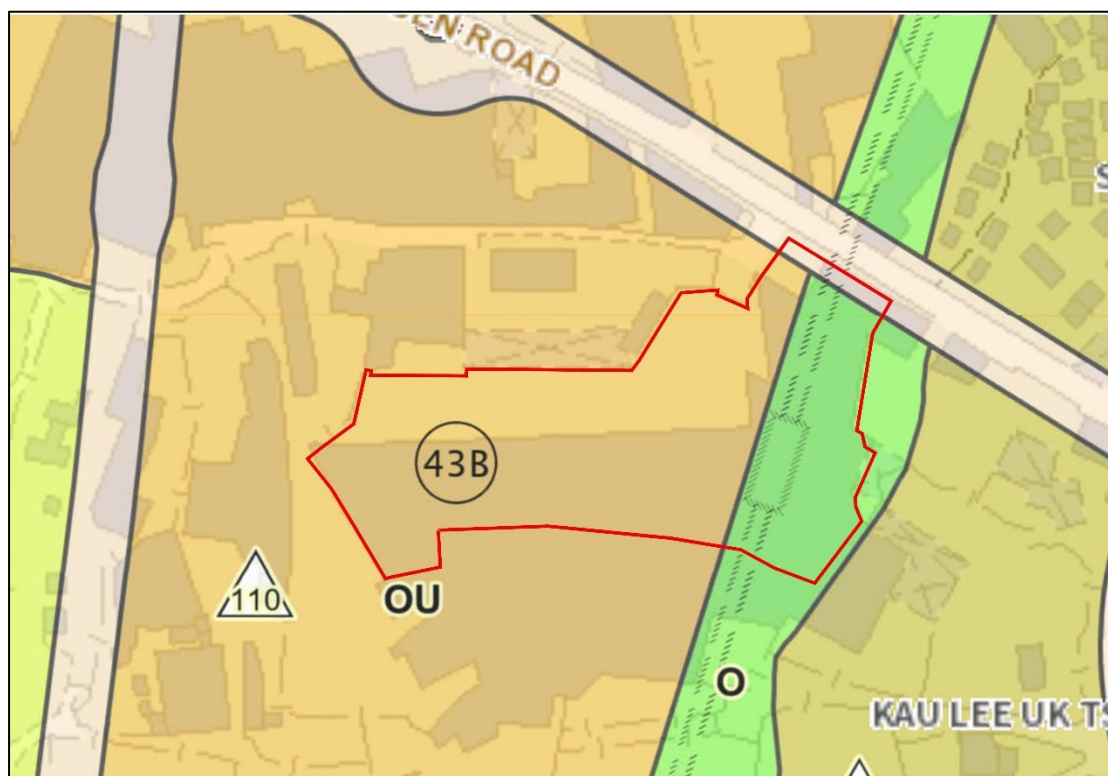

## **Appendix B**

### **Letter from Lands Department and Land**

### **Resumption Notice**



地政總署  
新發展區組  
NEW DEVELOPMENT AREA  
SECTION

電話 Tel: 3565 1371  
圖文傳真 Fax: 3565 4270  
電郵地址 Email: lep23@landsd.gov.hk  
本署檔號 Our Ref: (11) in LD NDA/HSK/SBUT/0070  
來函檔號 Your Ref:

我們矢志努力不懈，提供盡善盡美的土地行政服務。  
We strive to achieve excellence in land administration.

新界上水龍琛路 39 號上水廣場 15 樓 1501 至 1510 室  
Units 1501-10, Level 15, Landmark North,  
39 Lung Sum Avenue, Sheung Shui, New Territories.

網址 Website : www.landsd.gov.hk

覆函請註明本署檔號  
Please quote our reference in your reply

現場派遞

致：業務經營者

敬啟者：



洪水橋／厦村新發展區第二期發展工程

你在上址經營的露天／戶外業務，因上述工務計劃影響而須清拆。根據現行政策，在上址經營露天／戶外業務的經營者，如經調查確定符合資格後，將可獲發特惠津貼。其他未符合資格的人士，則不會獲發任何特惠津貼。

故現請你於 2024 年 2 月 1 日 或之前向本署提供下列文件的副本，以便評核你是否符合資格申領特惠津貼。

- (1) (a) 經營人之香港身份證 (b) 合夥人之香港身份證  
(c) 香港公司註冊證書
- (2) 有關業務在清拆前登記日 (即 2018 年 5 月 10 日) 前 2 年的營運單據：
- (a) 報稅單或繳稅單 (b) 營業損益表  
(c) 火險保單單據 (d) 僱員保險單據  
(e) 器材保養單據 (f) 商業登記證  
(g) 供電單據 (h) 電話單據  
(i) 供水單據 (j) 資訊服務單據

(3) 其他有效證明文件

本處將於稍後時間再與你聯絡以便查閱上述文件的正本。  
如有需要，本處可能要求你提供一切其他所需資料及文件。

如你對此事有任何查詢，請於辦公時間內致電 3565 1371  
與地政主任梁安迪先生聯絡。

地政總署

總產業測量師／新發展區

(梁安迪  代行)

2024年1月18日



地政總署  
新發展區組  
NEW DEVELOPMENT AREA SECTION  
LANDS DEPARTMENT

電話 Tel: 3590 3077  
圖文傳真 Fax: 3547 0756  
電郵地址 Email: slep4@landsd.gov.hk  
本署檔號 Our Ref: ( ) in LD NDA HSK/SBUT/0071  
來函檔號 Your Ref:  
來函請註明本署檔號  
Please quote our reference in your reply

我們矢志努力不懈，提供盡善盡美的土地行政服務。  
We strive to achieve excellence in land administration.

新界上水龍琛路 39 號上水廣場 15 樓 1501 至 1510 室  
Units 1501-10, Level 15, Landmark North,  
39 Lung Sum Avenue, Sheung Shui, New Territories.

網址 Website : www.landsd.gov.hk

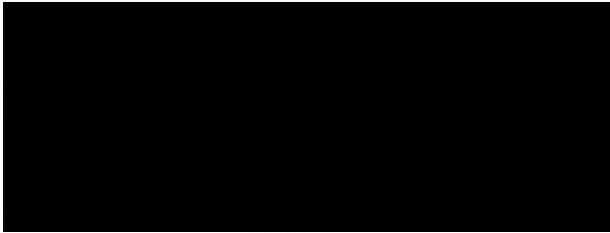

(經辦人：郭啟榮先生)

郭先生：

**洪水橋／厦村新發展區第二期發展工程**  
**業務經營者：Winpro Management Expert Limited**  
**清拆編號：H26/586 – 602, 607 – 623**

你／貴公司在上址經營的露天／戶外業務，因上述工務計劃影響而須遷出。本署已於 2025 年 4 月 8 日根據《土地(雜項條文)條例》(第 28 章)，在涉及的構築物及／或相關範圍張貼告示，通知你／貴公司須於 2025 年 7 月 10 日前停止佔用有關土地。

經審核後，你／貴公司符合領取露天／戶外業務經營者的特惠津貼資格，本署將向你／貴公司發放港幣 [REDACTED] 的特惠津貼。惟你／貴公司須將該等在用地上的不合資格構築物拆卸。

本署將於稍後通知你／貴公司前來領取特惠津貼。在領取特惠津貼前，你／貴公司需已經自願搬離有關土地及向政府交出所有受影響人士／業務遷出後的土地及騰空的構築物，並且需簽署一份彌償書。若你／貴公司希望在搬離有關土地前提早獲發特惠津貼，可聯絡本署以作安排，屆時你／貴公司需簽署一份承諾書承諾你／貴公司會於擬議及本署同意的「預定離場日」(不得遲於上述告示期限)或之前無條件自願搬離

有關土地及向政府交出所有受影響人士／業務遷出後的土地及騰空的構築物。在領取提早發放的特惠津貼時，你／貴公司亦需簽署一份彌償書。

本署在此提醒你／貴公司不能將上述經營範圍改作其他用途，並須於上述告示期限／「預定離場日」或之前無條件自願搬離有關土地，並向政府交出所有受影響人士／業務遷出後的土地及騰空的構築物。否則，本署可根據《土地(雜項條文)條例》(第 28 章)於任何時間採取適當的土地管制行動要求受影響人士／業務遷出有關土地及有關構築物。

日後，如你／貴公司能在上述告示期限／「預定離場日」之前提早向政府交出所有受影響人士／業務遷出後的土地及騰空的構築物，請盡快聯絡本署安排，而交回的土地及構築物內有任何留下的物件，本署會當棄置之廢物處理。

請注意，如你／貴公司同意領取露天／戶外業務經營者的特惠津貼，即表示同意以此作為完全及最終解決你／貴公司就政府收回有關土地的業務經營所提出的騷擾補償申索及同意放棄提出其他任何補償申索。

倘政府日後發現你／貴公司的特惠津貼申請有不誠實成分或提供失實資料，你／貴公司須在政府要求下立即全數償還有關特惠津貼連利息，否則政府會向你／貴公司提出有關法律行動。

如你／貴公司對此事有任何查詢，請於辦公時間內致電 3565 1371 與地政主任梁安迪先生聯絡。

總產業測量師／新發展區

(張凱欣



代行)

副本送：

地政總署新發展區組清拆小組 (經辦人：傅裕平先生)

2025 年 4 月 11 日

電話 Tel: 3590 3077  
圖文傳真 Fax: 3547 0756  
電郵地址 Email: slep4@landsd.gov.hk  
本署檔號 Our Ref: ( ) in LD NDA HSK/SBUT/0070  
來函檔號 Your Ref:  
來函請註明本署檔號  
Please quote our reference in your reply



地政總署  
新發展區組  
NEW DEVELOPMENT AREA SECTION  
LANDS DEPARTMENT

我們矢志努力不懈，提供盡善盡美的土地行政服務。  
We strive to achieve excellence in land administration.

新界上水龍琛路 39 號上水廣場 15 樓 1501 至 1510 室  
Units 1501-10, Level 15, Landmark North,  
39 Lung Sum Avenue, Sheung Shui, New Territories.

網址 Website : [www.landsd.gov.hk](http://www.landsd.gov.hk)

(經辦人：郭啟榮先生)

郭先生：

**洪水橋／厦村新發展區第二期發展工程**  
**業務經營者：Winpro Management Expert Limited**  
**清拆編號：H26/579-585, 624**

你／貴公司在上址經營的露天／戶外業務，因上述工務計劃影響而須遷出。本署已於 2025 年 4 月 8 日根據《土地(雜項條文)條例》(第 28 章)，在涉及的構築物及／或相關範圍張貼告示，通知你／貴公司須於 2025 年 7 月 10 日前停止佔用有關土地。

經審核後，你／貴公司符合領取露天／戶外業務經營者的特惠津貼資格，本署將向你／貴公司發放港幣 [REDACTED] 的特惠津貼。惟你／貴公司須將該等在用地上的不合資格構築物拆卸。

本署將於稍後通知你／貴公司前來領取特惠津貼。在領取特惠津貼前，你／貴公司需已經自願搬離有關土地及向政府交出所有受影響人士／業務遷出後的土地及騰空的構築物，並且需簽署一份彌償書。若你／貴公司希望在搬離有關土地前提早獲發特惠津貼，可聯絡本署以作安排，屆時你／貴公司需簽署一份承諾書承諾你／貴公司會於擬議及本署同意的「預定離場日」(不得遲於上述告示期限)或之前無條件自願搬離

有關土地及向政府交出所有受影響人士／業務遷出後的土地及騰空的構築物。在領取提早發放的特惠津貼時，你／貴公司亦需簽署一份彌償書。

本署在此提醒你／貴公司不能將上述經營範圍改作其他用途，並須於上述告示期限／「預定離場日」或之前無條件自願搬離有關土地，並向政府交出所有受影響人士／業務遷出後的土地及騰空的構築物。否則，本署可根據《土地(雜項條文)條例》(第 28 章)於任何時間採取適當的土地管制行動要求受影響人士／業務遷出有關土地及有關構築物。

日後，如你／貴公司能在上述告示期限／「預定離場日」之前提早向政府交出所有受影響人士／業務遷出後的土地及騰空的構築物，請盡快聯絡本署安排，而交回的土地及構築物內有任何留下的物件，本署會當棄置之廢物處理。

請注意，如你／貴公司同意領取露天／戶外業務經營者的特惠津貼，即表示同意以此作為完全及最終解決你／貴公司就政府收回有關土地的業務經營所提出的騷擾補償申索及同意放棄提出其他任何補償申索。

倘政府日後發現你／貴公司的特惠津貼申請有不誠實成分或提供失實資料，你／貴公司須在政府要求下立即全數償還有關特惠津貼連利息，否則政府會向你／貴公司提出有關法律行動。

如你／貴公司對此事有任何查詢，請於辦公時間內致電 3565 1371 與地政主任梁安廸先生聯絡。

總產業測量師／新發展區

(張凱欣



代行)

副本送：

地政總署新發展區組清拆小組 (經辦人：傅裕平先生)

2025 年 4 月 11 日

## LANDS RESUMPTION ORDINANCE (Chapter 124)

(Notice under section 4)

**RESUMPTION OF LAND FOR  
THE SECOND PHASE DEVELOPMENT OF HUNG SHUI KIU/HA TSUEN  
NEW DEVELOPMENT AREA (FIRST BATCH)**

To the owners and every person interested or having any right or easement in all those pieces or parcels of land in the New Territories more particularly described below and shown coloured orange on the Resumption Plan No. YLM11147b and also the land shown coloured orange stippled black on the Resumption Plan No. YLM11147b:—

Lots Nos. 300 RP (Portion), 301 S.B (Portion), 455 RP (Portion), 461 RP (Portion), 462 RP (Portion), 463 RP (Portion), 472 (Portion), 473 (Portion), 474 (Portion), 475 (Portion), 499 (Portion), 534 (Portion), 535 (Portion), 536 (Portion), 537 (Portion), 538 (Portion), 539 (Portion), 540 (Portion), 541 (Portion), 556 (Portion), 559 (Portion), 560 (Portion), 561 (Portion), 562 (Portion), 563 (Portion), 564 (Portion), 576 (Portion), 577 (Portion), 579 (Portion), 588 (Portion), 589 (Portion), 591, 592 (Portion), 593 (Portion), 1444 RP (Portion), 1462 RP (Portion), 1829 S.A ss.2 (Portion), 1829 S.A ss.3 (Portion), 1829 S.A ss.9 (Portion), 1829 S.A ss.14 (Portion), 1829 S.A RP (Portion) and 1829 RP (Portion) all in Demarcation District No. 121;

Lots Nos. 1, 2, 3, 4, 5, 6, 7 S.A, 7 S.B (Portion), 7 RP (Portion), 8 (Portion), 9 RP (Portion), 10 (Portion), 11 (Portion), 33 (Portion), 44 (Portion), 45 (Portion), 46 S.A, 46 S.B, 46 RP, 47, 48, 49, 50 (Portion), 51 (Portion), 52 (Portion), 53, 54, 55, 56, 57, 58, 60, 61, 62, 63 (Portion), 64 (Portion), 65, 66, 67 (Portion), 70 (Portion), 71 (Portion), 72 (Portion), 73 (Portion), 74 (Portion), 75 (Portion), 93 RP, 94, 95, 96, 97, 98, 99, 100 RP, 101 RP, 102 (Portion), 103 RP (Portion), 107 S.A (Portion), 107 RP, 108 S.A, 108 S.B (Portion), 111 (Portion), 112 (Portion), 113, 114 (Portion), 115 (Portion), 116, 117, 118, 119, 120, 121, 122, 123, 124 RP, 125, 127, 128, 129, 130 RP, 131, 132 RP, 133 RP, 134, 135 S.A, 135 S.B, 136 RP, 144 RP, 146 RP, 147 RP, 153 RP, 154, 155, 156, 157 RP, 158 RP, 159 RP, 160 RP, 161, 163 RP, 164 RP, 217 RP, 218, 219 RP, 220 RP, 221 RP, 222, 223, 224, 225, 226, 227, 228, 229, 230, 231, 232, 233, 234, 235, 236 S.A, 236 S.B, 237, 238, 239, 240, 241, 242 (Portion), 244 (Portion), 245 (Portion), 246, 247, 248, 249 (Portion), 250 S.A, 250 S.B (Portion), 251 (Portion), 252, 253, 254, 255, 256, 257, 258, 259, 260, 261, 262, 263, 264, 265, 266, 267, 268, 269, 270, 271, 272 RP, 273, 274, 275 S.A [also known as 275A; and also known as 275(A)], 276, 277, 278, 280, 281 RP, 282 RP, 283 RP, 284 RP, 479 RP, 480 S.A RP (Portion), 480 RP (Portion), 481 (Portion), 482 (Portion), 483 (Portion), 484, 485, 486, 487 S.A, 487 S.B, 488, 489 S.A [also known as 489A; and also known as 489(A)], 489 S.B RP [also known as 489B RP; and also known as 489(B) RP], 490 RP, 491 RP, 494 RP, 495 RP, 496, 497, 498, 499, 500, 501 RP, 504 RP, 505, 506, 509 RP, 510, 511, 512, 513 RP, 514, 515 RP, 519 RP (Portion), 520 RP (Portion), 522 (Portion), 523 (Portion), 538 (Portion), 540 (Portion), 609 RP (Portion), 610 (Portion), 611, 612, 614, 615, 616, 617 (Portion), 619 (Portion), 622 (Portion), 623 (Portion), 624, 625, 626, 627, 628, 629, 630, 631, 632, 633, 634 (Portion), 635 (Portion), 636 S.B RP (Portion), 637 RP (Portion), 638 RP (Portion), 639 RP (Portion), 649 RP (Portion), 650 (Portion), 676 RP, 980 RP, 987 RP, 988 RP, 989 RP, 991 RP, 992 RP, 994, 995, 996, 997, 999, 1001 RP, 1129 S.B, 1129 RP, 1154 S.C, 1154 RP, 1155 RP, 1156 RP, 1157 RP, 1158 RP, 1160 RP, 1162 S.C (Portion), 1162 RP (Portion), 1172 RP, 1173 RP, 1175 RP, 1178, 1179 RP, 1180, 1181 S.B (Portion), 1182 RP (Portion), 1183, 1184 (Portion), 1185, 1186, 1187, 1188 (Portion), 1189, 1190 S.A (Portion), 1190 S.B (Portion), 1190 S.C (Portion), 1190 S.D, 1190 RP (Portion), 1191 (Portion), 1203 (Portion), 1206 (Portion), 1207 (Portion), 1208, 1209, 1210 (Portion), 1211 RP (Portion), 1225 (Portion), 1226 RP (Portion), 1236 S.A ss.1 RP (Portion), 1236 S.B (Portion), 1237 (Portion), 1238, 1239, 1240 S.A, 1240 RP, 1241 S.A, 1241 RP (Portion), 1242 S.A ss.1, 1242 S.A RP, 1242 S.B, 1243 (Portion), 1244, 1245, 1246, 1247, 1248, 1249 (Portion), 1250 (Portion), 1254 S.A, 1254 RP, 1255, 1256, 1257, 1258, 1259, 1260, 1261, 1262, 1263 (Portion), 1264 S.A (Portion), 1264 RP, 1265, 1266, 1267 (Portion), 1268 (Portion), 1270, 1272, 1273, 1274, 1275, 1276 S.A, 1276 RP, 1277, 1278, 1279, 1280, 1283 (Portion), 1292, 1293, 1294, 1296, 1297, 1308 RP (Portion), 1314 RP (Portion), 1315 RP (Portion), 1316 (Portion), 1318 (Portion), 1320 (Portion), 1322 (Portion), 1323, 1324, 1325, 1326 (Portion), 1327 (Portion), 1329 (Portion), 1330 (Portion), 1331 (Portion), 1332, 1335, 1336 (Portion), 1337 S.A, 1337 RP (Portion), 1338, 1339, 1340, 1341, 1342, 1343, 1344, 1345,

1346 (Portion), 1347 (Portion), 1353 (Portion), 1354 (Portion), 1355 (Portion), 1357 (Portion), 1358 (Portion), 1359, 1360, 1361, 1362 (Portion), 1363 (Portion), 1365, 1366, 1367 (Portion), 1368 (Portion), 1369 (Portion), 1370 (Portion), 1371 (Portion), 1372 (Portion), 1373 (Portion), 1374 (Portion), 1375 (Portion), 1376 (Portion), 1377, 1378, 1379, 1380, 1381, 1382 (Portion), 1383 (Portion), 1384 (Portion), 1385 (Portion), 1386, 1387 (Portion), 1388 (Portion), 1389, 1390, 1391 (Portion), 1392 (Portion), 1393, 1394 (Portion), 1395 (Portion), 1396 (Portion), 1397 (Portion), 1398, 1399, 1400 (Portion), 1401, 1402, 1403, 1404 (Portion), 1405 (Portion), 1406 (Portion), 1407 (Portion), 1408 (Portion), 1410 (Portion), 1411, 1412, 1413, 1414, 1415 (Portion), 1416 (Portion), 1417, 1418, 1419, 1420 (Portion), 1421 (Portion), 1422, 1423 (Portion), 1424 (Portion), 1425 (Portion), 1426, 1427, 1428 (Portion), 1429, 1430, 1431, 1432, 1433 (Portion), 1434, 1435, 1436 (Portion), 1437 (Portion), 1438 (Portion), 1439 (Portion), 1440 (Portion), 1441 (Portion), 1442 (Portion), 1443 (Portion), 1444, 1445, 1446, 1447, 1448, 1449 (Portion), 1450 (Portion), 1451, 1452, 1453, 1454 RP (Portion), 1455, 1456, 1457 (Portion), 1458 (Portion), 1459, 1460, 1461 (Portion), 1462, 1463, 1464, 1465, 1467 (Portion), 1468 (Portion), 1469 (Portion), 1470, 1471 (Portion), 1472 (Portion), 1473 (Portion), 1474, 1475, 1476, 1477, 1478, 1479, 1480, 1481, 1482, 1483, 1484, 1485, 1486 (Portion), 1487 (Portion), 1488 (Portion), 1489, 1490, 1491, 1492, 1493, 1494 (Portion), 1495 (Portion), 1496 (Portion), 1499 RP (Portion), 1502 RP, 1503 RP, 1504 RP, 1507 RP (Portion), 1508 (Portion), 1509 RP (Portion), 1510 RP (Portion), 1511 (Portion), 1513 (Portion), 1514, 1515, 1516, 1517, 1518 (Portion), 1519 (Portion), 1520 (Portion), 1521, 1522 (Portion), 1523 (Portion), 1524 (Portion), 1533, 1534, 1537, 1538, 1539 RP, 1543 RP, 1544 RP, 1547 RP (Portion), 1548 S.A (Portion), 1548 S.B RP (Portion), 1553 (Portion), 1554 S.A, 1554 RP, 1555 RP, 1556 RP (Portion), 1557 (Portion), 1562 RP (Portion), 1563 (Portion), 1564 (Portion), 1565 (Portion), 1566, 1567, 1568 (Portion), 1569, 1570, 1571, 1572, 1573, 1574 (Portion), 1575 (Portion), 1576 (Portion), 1577 (Portion), 1578 (Portion), 1579, 1580 (Portion), 1581 (Portion), 1582 (Portion), 1583 (Portion), 1584 RP (Portion), 1585 (Portion), 1586 (Portion), 1587 (Portion), 1588 (Portion), 1589 (Portion), 1590, 1591 (Portion), 1592 (Portion), 1593, 1594, 1595, 1596, 1597, 1598, 1599, 1600 (Portion), 1602 (Portion), 1603 (Portion), 1604 (Portion), 1605 (Portion), 1606 (Portion), 1608 RP (Portion), 1613 (Portion), 1614 RP (Portion), 1615 RP (Portion), 1616 RP (Portion), 1622 (Portion), 1623 (Portion), 1624 (Portion), 1626 RP (Portion), 1627 (Portion), 1629 RP (Portion), 1630 RP (Portion), 1631 RP (Portion), 1633 RP, 1634 (Portion), 1635 S.A RP (Portion), 1635 RP (Portion), 1636 RP (Portion), 1637 RP (Portion), 1639 RP (Portion), 1640 RP (Portion), 1641 RP (Portion), 1643 (Portion), 1644 (Portion), 1645 (Portion), 1646 (Portion), 1647 (Portion), 1648, 1649, 1650, 1651 S.A, 1651 S.B, 1651 S.C, 1651 S.D, 1652, 1653, 1654, 1655, 1656, 1657, 1658 S.A, 1658 RP, 1659, 1660 S.A, 1660 S.B, 1660 S.C, 1660 RP, 1661, 1662, 1663, 1664, 1665 (Portion), 1666, 1667, 1668, 1669, 1671 S.A, 1671 S.B, 1671 RP, 1672, 1673 S.A, 1673 S.B, 1673 RP (Portion), 1675 (Portion), 1676 (Portion), 1677 (Portion), 1678 (Portion), 1679, 1680, 1681, 1682, 1683, 1684, 1685, 1689, 1690, 1691, 1692, 1693, 1694 (Portion), 1695 (Portion), 1696, 1697, 1698, 1699 (Portion), 1700, 1701 (Portion), 1702 (Portion), 1703 (Portion), 1704, 1705, 1706 (Portion), 1711 RP (Portion), 1712 RP (Portion), 1713 RP (Portion), 1715 RP (Portion), 1716 RP, 1719 RP, 1720 RP, 1729 RP, 1730 RP (Portion), 1734 RP (Portion), 1735 RP (Portion), 1741 RP (Portion), 1849 S.A RP, 1850 S.A ss.1 RP, 1850 S.A ss.2 RP, 1851 S.A RP, 1852 S.A ss.1 RP, 1921 S.A RP, 1926 RP, 1927 RP (Portion), 1950 (Portion), 1951 RP (Portion), 1952 S.A, 1952 S.B RP, 1952 RP, 1953 S.B (Portion), 1953 S.F (Portion), 1954 (Portion), 2033 (Portion), 2153 (Portion), 2162 (Portion), 2164 (Portion), 2165 (Portion), 2166, 2167 (Portion), 2168 (Portion), 2169 (Portion), 2171 (Portion), 2172 (Portion), 2173, 2174, 2175, 2176, 2177, 2178, 2179, 2180, 2181 (Portion), 2182 (Portion), 2183 (Portion), 2184 (Portion), 2185 S.A, 2185 S.B, 2185 S.C, 2186 (Portion), 2187 (Portion), 2188, 2189, 2190, 2191, 2192, 2193 S.A, 2193 S.B, 2193 RP, 2194, 2195, 2196, 2197, 2198, 2199, 2200 S.A, 2200 S.B, 2200 RP, 2201 (Portion), 2202 (Portion), 2203 (Portion), 2204, 2205, 2206, 2207 S.A ss.1 S.A, 2207 S.A ss.1 RP, 2207 S.A ss.2 RP (Portion), 2207 S.A ss.3, 2207 S.A ss.4, 2207 S.A ss.5 (Portion), 2207 S.A ss.6, 2207 S.A ss.7 (Portion), 2207 S.A ss.8 (Portion), 2207 S.A ss.9, 2207 S.A ss.10 S.A, 2207 S.A ss.10 RP (Portion), 2207 S.A RP (Portion), 2208, 2209 S.A RP, 2209 S.B ss.1 S.B (Portion), 2209 S.B ss.1 RP (Portion), 2210, 2212 RP, 2213 RP (Portion), 2214 RP (Portion), 2347 RP, 2353 RP, 2354 RP, 2358 RP, 2361 RP, 2362, 2363, 2364, 2365, 2366 RP, 2367, 2368, 2369 RP, 2371 RP, 2373 RP, 2377 RP, 2404 RP, 2405 RP, 2406 RP, 2407 RP, 2408 RP, 2409, 2410 S.A ss.1, 2410 S.A RP, 2410 S.B, 2410 RP, 2411 S.A ss.1, 2411 S.A RP, 2411 RP, 2412, 2413, 2414 RP, 2415 RP, 2416 RP, 2417 RP, 2421 RP, 2422 RP, 2424 RP, 2425 RP, 2427 RP, 2428 RP, 2429 RP, 2438 S.C RP, 2840 RP, 2842 S.A, 2842 RP, 2843, 2844, 2845, 2846, 2847 RP, 2848 RP, 2849 RP, 2850, 2851 RP, 2852 RP, 2937 RP (Portion), 2942, 2943, 2944, 2945, 2946 (Portion), 2947 (Portion), 2949 S.A (Portion), 2950 (Portion), 2951 (Portion), 2952, 2953 S.A (Portion), 2953 S.B (Portion), 2960 (Portion), 2961 (Portion), 2962, 2963, 2964,

2965 RP, 2966, 2967 RP, 2968 S.B RP, 2969 S.B ss.3, 2969 S.B ss.4, 2969 S.B RP, 2972 RP (Portion), 2973 RP (Portion), 2974 RP, 3086 S.A ss.1, 3086 S.A RP (Portion), 3088 RP (Portion), 3091 (Portion), 3092 (Portion), 3093 (Portion), 3094 (Portion), 3095, 3096, 3097 (Portion), 3098, 3099 (Portion), 3100 (Portion), 3101 (Portion), 3102 (Portion), 3109, 3110, 3111, 3112, 3113 (Portion), 3114 (Portion), 3115 (Portion), 3116 S.A (Portion), 3116 S.B (Portion), 3117 S.A (Portion), 3117 S.B, 3118 (Portion), 3119 (Portion), 3120, 3122 (Portion), 3123 (Portion), 3124, 3125, 3126, 3127, 3128, 3129, 3130, 3131, 3132 RP (Portion), 3133 RP (Portion), 3134 RP (Portion), 3135 RP, 3136 RP (Portion), 3138 RP (Portion), 3139 (Portion), 3140, 3141 (Portion), 3148, 3152 (Portion), 3153, 3154, 3155, 3156, 3157, 3158, 3159 (Portion), 3160 (Portion), 3161 RP, 3162, 3163, 3164, 3165, 3166, 3167, 3168, 3169, 3170 (Portion), 3172 (Portion), 3173, 3174, 3175, 3177 (Portion), 3178 (Portion), 3180 RP (Portion), 3192 RP, 3199, 3200, 3201, 3202, 3203 (Portion), 3205 RP (Portion), 3206 RP (Portion), 3225 RP (Portion), 3226 RP (Portion), 3228 RP (Portion), 3231 (Portion), 3232 (Portion), 3233, 3234 (Portion), 3235 (Portion), 3236 RP (Portion), 3237 (Portion), 3238 RP (Portion), 3242 RP (Portion), 3243 RP (Portion), 3245 (Portion), 3247 (Portion), 3248 (Portion), 3256 (Portion), 3259 (Portion), 3260 (Portion), 3263 (Portion), 3264 (Portion), 3265 (Portion), 3268 (Portion), 3270 (Portion), 3272 (Portion), 3280 RP, 3281, 3282, 3283 (Portion), 3285 RP (Portion), 3286 (Portion), 3287, 3289 (Portion), 3299 (Portion), 3300 (Portion), 3302 (Portion), 3303 (Portion), 3304 (Portion), 3305 (Portion), 3307 (Portion), 3310 RP (Portion), 3311 S.A [formerly known as 3311 RP (Portion)], 3311 S.B [formerly known as 3311 RP (Portion)], 3311 S.C [formerly known as 3311 RP (Portion)], 3311 RP (Portion), 3312 RP (Portion), 3313 RP (Portion), 3314 RP (Portion), 3415 (Portion), 3416 RP (Portion), 3419 (Portion), 3420 RP, 3424 RP, 3426 (Portion), 3427 (Portion), 3428 RP, 3429 RP (Portion), 3430 RP (Portion), 3431 RP (Portion), 3432 S.A (Portion), 3432 S.B, 3432 RP (Portion), 3433 RP (Portion), 3437 (Portion), 3438 (Portion), 3440 (Portion), 3441 RP (Portion), 3442 RP (Portion), 3443 RP (Portion), 3444 (Portion), 3445 (Portion), 3446 (Portion), 3447 RP (Portion), 3448 (Portion), 3449 (Portion), 3450 (Portion), 3451, 3452 (Portion), 3453 (Portion), 3454 (Portion), 3460 RP (Portion), 3461 RP, 3464 S.A, 3464 RP, 3465, 3466 S.A ss.1, 3466 S.A RP, 3466 S.B ss.1, 3466 S.B RP, 3467, 3468 RP, 3469 RP, 3470, 3471 (Portion), 3472 (Portion), 3481 (Portion), 3482 (Portion), 3483 (Portion), 3484, 3485, 3486, 3487, 3488, 3489, 3490, 3491, 3492, 3493, 3494, 3495, 3496, 3497, 3498, 3499 (Portion), 3500, 3501, 3502, 3503, 3504 S.A, 3504 RP, 3505, 3506 S.A, 3506 RP, 3508, 3509, 3510, 3511, 3512, 3513, 3514, 3515 S.A, 3515 RP, 3516, 3517 RP (Portion), 3518, 3519 (Portion), 3520 (Portion), 3521 (Portion), 3522 RP (Portion), 3523 (Portion), 3524 RP (Portion), 3527 RP (Portion), 3528 RP (Portion), 3529 RP (Portion), 3530 (Portion), 3531 (Portion), 3532, 3533, 3534 (Portion), 3535 (Portion), 3536 (Portion), 3537 (Portion), 3538 (Portion), 3539 (Portion), 3540 (Portion), 3542, 3544 (Portion), 3545 (Portion), 3546 (Portion), 3549 (Portion), 3552 (Portion), 3553 (Portion), 3554 (Portion), 3555, 3556 (Portion), 3557 (Portion), 3558 (Portion), 3559, 3560, 3561 RP (Portion), 3563 (Portion), 3571, 3572 RP, 3573 RP, 3577 RP, 3578, 3579, 3580, 3581, 3582, 3583, 3584, 3585, 3586, 3587 RP, 3588 S.A ss.1, 3588 S.A RP, 3588 S.B, 3588 S.C, 3588 S.D, 3588 RP, 3589, 3590, 3591, 3592, 3593, 3594, 3595 (Portion), 3596, 3597, 3598 (Portion), 3599 (Portion), 3601 (Portion), 3603 (Portion), 3604 (Portion), 3605 (Portion), 3608 (Portion), 3609 (Portion), 3610, 3611, 3612, 3613, 3614 (Portion), 3615 (Portion), 3616 (Portion), 3619 (Portion), 3620 (Portion), 3621 (Portion), 3622 (Portion), 3623, 3624 (Portion), 3625, 3626, 3627 (Portion), 3628 (Portion), 3629, 3630, 3631, 3632, 3633, 3634, 3635 S.A, 3635 S.B, 3635 S.C RP, 3635 S.D RP, 3635 RP, 3636 RP, 3637, 3638, 3639 S.A, 3639 RP, 3640 RP, 3644 RP, 3645, 3646 RP, 3650 RP, 3901, 3934 RP (Portion), 3936 (Portion), 3937 (Portion), 3938 (Portion), 4075 RP, 4102, 4155 and 7001 all in **Demarcation District No. 124;**

Lots Nos. 136 (Portion), 147 (Portion), 148 (Portion), 150 (Portion), 157 (Portion), 158 (Portion), 159 (Portion), 160, 161 (Portion), 162, 163 (Portion), 164 (Portion), 165 (Portion), 166 (Portion), 167, 168, 169 (Portion), 170, 171, 172 (Portion), 173 (Portion), 175 (Portion), 176 (Portion), 177 (Portion), 181 (Portion), 182 (Portion), 183 (Portion), 184 (Portion), 186 (Portion), 187 (Portion), 191 (Portion), 197 (Portion), 200 (Portion), 202 (Portion), 203 (Portion), 204 (Portion), 206 (Portion), 219 (Portion), 220 (Portion), 223 (Portion), 238 (Portion), 257 (Portion), 258 (Portion), 259, 261 S.A (Portion), 261 RP (Portion), 275 (Portion), 276 (Portion), 277 (Portion), 278 (Portion), 279 (Portion), 280 (Portion), 282 (Portion), 285 (Portion), 287, 289, 290, 291, 292, 293, 294, 295 (Portion), 296 (Portion), 297 (Portion), 298, 299, 300, 301, 302, 303 (Portion), 304 (Portion), 305, 306, 307, 308 (Portion), 316 (Portion), 317 (Portion), 320 (Portion), 322 (Portion), 323 (Portion), 324 (Portion), 325 (Portion), 326 (Portion), 371 (Portion), 373 (Portion), 374 (Portion), 375 (Portion), 394 (Portion), 395 (Portion), 396 (Portion), 399 RP (Portion), 452 RP (Portion), 458 S.A RP

(Portion), 496 RP (Portion), 515 RP, 516 (Portion), 517 (Portion), 518 (Portion), 519 (Portion), 520 (Portion), 545 (Portion), 546 S.A (Portion), 547 (Portion), 572 (Portion), 573 (Portion), 574 (Portion), 577 (Portion), 578 (Portion), 579 (Portion), 667, 668, 669, 670, 671, 672, 673, 674, 675 S.A, 675 S.B, 676, 677 (Portion), 679 S.A, 679 S.B, 679 S.C, 679 S.D, 679 S.E, 679 S.F (Portion), 679 S.G ss.1 (Portion), 679 RP (Portion), 680 (Portion), 681 (Portion), 682 (Portion), 699 (Portion), 700 (Portion), 702, 703, 704 (Portion), 705 (Portion), 706, 707, 708, 709, 710, 711 (Portion), 713 (Portion), 714 (Portion), 716 S.C, 716 RP, 717 (Portion), 718, 719 (Portion), 720 (Portion), 721 (Portion), 722, 723, 724, 725, 726, 727 (Portion), 728 (Portion), 729 (Portion), 730 (Portion), 731 (Portion), 732, 733 (Portion), 734 (Portion), 735, 736 (Portion), 737 (Portion), 738, 739, 744 (Portion), 745 (Portion), 750 (Portion), 751 (Portion), 752, 753, 754, 755, 756 (Portion), 757 (Portion), 758 (Portion), 759 (Portion), 760 (Portion), 761, 762, 763, 764 (Portion), 766 (Portion), 768 (Portion), 769 (Portion), 770 S.A, 770 S.B (Portion), 817 S.A RP (Portion), 817 S.B RP (Portion), 818 S.B RP (Portion), 1103 RP (Portion), 1104 RP (Portion), 1138 (Portion), 1139 S.A RP (Portion), 1139 RP (Portion), 1140 (Portion), 1141 RP (Portion), 1142, 1143 RP, 1144 S.F (Portion), 1145 (Portion), 1146 (Portion), 1151 (Portion), 1152 (Portion), 1153, 1154 RP, 1155, 1156, 1157, 1158, 1159 (Portion), 1160 (Portion), 1161 (Portion), 1162, 1163, 1164, 1165, 1166, 1168, 1169 RP (Portion), 1170 RP (Portion), 1175 RP, 1176 RP (Portion), 1177, 1179, 1180, 1181, 1183 RP, 1185 RP, 1187 RP (Portion), 1188 RP (Portion), 1189 RP (Portion), 1190, 1191 (Portion), 1192 (Portion), 1193, 1194, 1195 (Portion), 1196, 1197 (Portion), 1198 (Portion), 1199 S.B (Portion), 1200 (Portion), 1202 S.B (Portion), 1203 (Portion), 1205 (Portion), 1206 (Portion), 1207 (Portion), 1208 (Portion), 1213 (Portion), 1214 (Portion), 1215 (Portion), 1216, 1217, 1218, 1219, 1220 (Portion), 1221 (Portion), 1222 (Portion), 1223 (Portion), 1224, 1225, 1226 S.A, 1226 S.B, 1227, 1228 (Portion), 1229 RP (Portion), 1230, 1231 RP (Portion), 1232, 1233, 1234, 1235 (Portion), 1238 (Portion), 1239, 1240, 1241, 1242, 1243 RP (Portion), 1244 RP (Portion), 1247 RP, 1248, 1249, 1256 RP (Portion), 1306 RP (Portion), 1307 RP (Portion), 1308 (Portion), 1309 (Portion), 1310 S.A, 1310 RP, 1311 (Portion), 1313 (Portion), 1314 (Portion), 1315 (Portion), 1316, 1319 S.A RP (Portion), 1324 RP (Portion), 1326 RP (Portion), 1327 (Portion), 1328 (Portion), 1329, 1330, 1331, 1332, 1333, 1334 (Portion), 1335 (Portion), 1336, 1337, 1338, 1339, 1340, 1341 (Portion), 1342 S.B (Portion), 1457 RP (Portion), 1458 RP (Portion), 1459 S.A, 1459 RP (Portion), 1460, 1461, 1462, 1463, 1464, 1465, 1466, 1467 S.A, 1467 S.B, 1467 S.C, 1467 S.D, 1467 RP, 1468, 1469, 1470, 1471, 1472, 1473, 1474 (Portion), 1475 RP (Portion), 1476 RP (Portion), 1477 (Portion), 1478, 1479 RP (Portion), 1480 RP (Portion), 1481 S.B RP (Portion), 1482 RP (Portion), 1483, 1484 RP (Portion), 1485, 1486 RP (Portion), 1488 RP (Portion), 1489 RP (Portion), 1491 RP (Portion), 1492 RP (Portion), 1493 (Portion), 1494, 1495, 1496, 1497, 1498 S.A ss.2 (Portion), 1498 S.A RP (Portion), 1498 S.B RP (Portion), 1499 RP (Portion), 1500 (Portion), 1501 RP (Portion), 1502 RP (Portion), 1503 RP (Portion), 1504, 1505 S.A (Portion), 1505 RP, 1506 (Portion), 1507, 1508 RP (Portion), 1509, 1510 RP (Portion), 1511 S.B, 1511 RP (Portion), 1512, 1513 (Portion), 1514, 1515, 1516, 1517, 1518, 1519, 1520, 1521, 1522, 1523, 1524, 1525, 1526, 1527 RP (Portion), 1528 RP (Portion), 1529 RP (Portion), 1530 RP (Portion), 1531 (Portion), 1532, 1533, 1534, 1535, 1536, 1537, 1538 RP (Portion), 1539 (Portion), 1540 (Portion), 1541 RP (Portion), 1542 RP (Portion), 1543 (Portion), 1544 (Portion), 1545, 1546 (Portion), 1547 (Portion), 1548, 1549 (Portion), 1550 (Portion), 1551 (Portion), 1598 RP (Portion), 1599 (Portion), 1600 (Portion), 1602 (Portion), 1605 (Portion), 1606 (Portion), 1607 (Portion), 1608 S.B (Portion), 1610 (Portion), 1611, 1612, 1613, 1614, 1615 S.A, 1615 S.B, 1616, 1617, 1618 RP, 1619 RP, 1667 S.B RP (Portion), 1670 RP (Portion), 1671 S.B RP (Portion), 1674 RP (Portion), 1676 RP (Portion), 1677 S.B (Portion), 1678 RP, 1679, 1680, 1681, 1682 (Portion), 1684 S.B (Portion), 1748 (Portion), 1749 (Portion), 1750 (Portion), 1751 (Portion), 1752 (Portion), 1757 RP (Portion), 1993 S.B RP, 1994 S.B RP, 1995 RP, 1996 RP, 1997, 1998 RP (Portion), 1999 (Portion), 2001 (Portion), 2002 (Portion), 2003 (Portion), 2004, 2005, 2006, 2007 RP, 2008 RP and 2009 RP all in **Demarcation District No. 125**; and

Lots Nos. 1674 RP (Portion), 1680 (Portion), 1682 (Portion), 1685 RP (Portion), 1686 (Portion), 1687 RP (Portion), 1690 (Portion), 1691 (Portion), 1692 (Portion), 1693 (Portion), 1694 (Portion), 1695 (Portion), 1696 (Portion), 1704 (Portion), 1705, 1706, 1707 (Portion), 1708, 1709 RP (Portion), 1711 RP (Portion), 1719 RP (Portion), 1720 RP (Portion), 1721 RP (Portion), 1722 RP (Portion), 1724 RP (Portion), 1725, 1726 RP, 1727 RP, 1728, 1729, 1730 RP, 1731 RP, 1732 RP, 1733 (Portion), 1734 (Portion), 1735 (Portion), 1736 RP (Portion), 1738 RP (Portion), 1739 RP (Portion), 1740 RP (Portion), 1741 RP, 1742 (Portion), 1743, 1744, 1745 (Portion), 1746 (Portion), 1747 (Portion), 1748 (Portion), 1749 (Portion), 1750 (Portion), 1751 (Portion), 1752 (Portion), 1753 (Portion), 1754 (Portion), 1755 (Portion), 1756 (Portion), 1759 (Portion), 1761 (Portion), 1762 RP (Portion), 1764 RP (Portion), 1765

RP (Portion), 1766 S.C (Portion), 1766 S.D RP (Portion), 1766 S.F RP (Portion), 1766 RP (Portion), 1767 RP (Portion), 1768 RP (Portion), 1772 RP (Portion), 1774 (Portion), 1775 (Portion), 1776 (Portion), 1779 S.A RP (Portion), 1779 S.B ss.1 (Portion), 1779 S.B RP (Portion), 1779 S.C (Portion), 1779 RP (Portion), 1781 (Portion), 1784 (Portion), 1785 (Portion), 1786, 1787, 1788 S.A, 1788 S.B, 1788 S.C ss.1, 1788 S.C RP, 1788 RP, 1789, 1790, 1791, 1792, 1793, 1794, 1795, 1796, 1797, 1798, 1799, 1800, 1801, 1802, 1803 RP (Portion), 1804 RP (Portion), 1805 RP, 1807 RP, 1808 (Portion), 1809 S.A, 1809 RP, 1810 RP (Portion), 1811, 1812, 1813 RP (Portion), 1817 RP (Portion), 1820 RP (Portion), 1824 RP (Portion), 1825 S.A (Portion), 1825 RP (Portion), 1832 (Portion), 1833 (Portion), 1834 S.A, 1834 RP, 1835 (Portion), 1836 (Portion), 1837 RP, 1838 RP, 1839 (Portion), 1840 RP (Portion), 1841 RP (Portion), 1842 RP, 1843 RP, 1844 RP, 1845 RP, 1846 (Portion), 1847 (Portion), 1849 RP (Portion), 1850 RP (Portion), 1852 RP (Portion), 1853 RP, 1854, 1855, 1856 (Portion), 1857, 1858, 1859, 1860, 1861, 1862 (Portion), 1864 RP (Portion), 1865 RP (Portion), 1866 RP (Portion), 1867, 1868, 1869, 1870, 1871, 1872, 1873, 1874, 1875 (Portion), 1876 RP (Portion), 1877 (Portion), 1878, 1879, 1880, 1881 (Portion), 1883 RP (Portion), 1884 RP, 1885 RP, 1892 (Portion), 1894 (Portion), 1895 RP (Portion), 1896 S.A (Portion), 1896 RP, 1897, 1898, 1899, 1900, 1901, 1902, 1903 RP (Portion), 1904 RP, 1905 RP, 1906 RP, 1907 RP, 1908 RP, 1909, 1910, 1911, 1912, 1913, 1914 (Portion), 1915, 1916, 1917, 1918 (Portion), 1919, 1920, 1921, 1922, 1923, 1924, 1925 (Portion), 1926, 1927 (Portion), 1928, 1929 RP, 1930 RP (Portion), 1931 (Portion), 1932 RP (Portion), 1935 (Portion), 1936 (Portion), 1937 (Portion), 1938 (Portion), 1939 (Portion), 1940 S.A (Portion), 1941 S.A (Portion), 1941 RP (Portion), 1942 (Portion), 1943, 1944, 1945, 1946, 1947, 1948 (Portion), 1949 (Portion), 1950 (Portion), 1951 (Portion), 1952 (Portion), 1953 (Portion), 1954 (Portion), 2053 S.B RP (Portion), 2063 S.B RP (Portion), 2064 S.B ss.2, 2064 S.B ss.3, 2064 S.B ss.4 RP, 2064 S.B RP, 2064 S.D RP, 2064 S.E, 2064 S.F, 2064 S.G RP, 2064 RP, 2102 RP, 2103, 2104, 2105, 2106, 2107, 2108, 2109, 2110, 2111, 2112, 2113, 2114 (Portion), 2115 (Portion), 2116 (Portion), 2117 (Portion), 2118, 2119 (Portion), 2120 (Portion), 2121, 2122, 2123, 2124, 2125, 2126, 2127, 2128 (Portion), 2129 (Portion), 2130, 2131, 2132 S.A, 2132 RP, 2133 RP, 2134 RP, 2140 RP, 2141, 2143 (Portion), 2144 RP (Portion), 2171 RP, 2172, 2173 (Portion), 2174 S.A, 2174 RP, 2175 S.A (Portion), 2175 S.B, 2175 RP, 2176 (Portion), 2177 (Portion), 2179 (Portion), 2180 (Portion), 2181 (Portion), 2182, 2183 S.B, 2184, 2185 (Portion), 2186 (Portion), 2187 (Portion), 2188 (Portion), 2189 (Portion), 2190 (Portion), 2191 S.A ss.1, 2191 S.A ss.2, 2191 S.A RP, 2191 S.B (Portion), 2191 S.C, 2191 S.D, 2191 RP, 2192, 2193, 2194, 2195, 2196 RP, 2197 RP, 2198 RP, 2526 (Portion), 2562, 2739, 2759 and 2760 all in Demarcation District No. 130.

TAKE NOTICE that the Chief Executive in Council has decided that the above-mentioned land is required for a public purpose, and under powers delegated by the Chief Executive of the Hong Kong Special Administrative Region, I have made an order that the above-mentioned land shall be resumed and revert to the Government of the Hong Kong Special Administrative Region on the expiration of THREE MONTHS from the date of the affixing of this notice to the said land.

This notice was affixed to the above-mentioned land on 30 May 2024. Upon expiration of the notice period at midnight on 30 August 2024, the above-mentioned land shall revert to the Government of the Hong Kong Special Administrative Region. The date of reversion shall be 31 August 2024.

The electronic version of this notice and the aforesaid Resumption Plan may be viewed on the Lands Department website (<https://www.landsd.gov.hk/en/resources/gov-notices/acq.html>) under Government Notices after this notice is published in the *Gazette*. A copy of this notice and the aforesaid Resumption Plan may be inspected by members of the public, free of charge, at the following offices during the following hours when those offices are normally open to the public:—

*Offices*

Central and Western Home Affairs Enquiry Centre,  
Ground Floor, Harbour Building,  
38 Pier Road, Central, Hong Kong

Tuen Mun Home Affairs Enquiry Centre,  
2nd Floor, Tuen Mun Government Offices,  
No. 1 Tuen Hi Road, Tuen Mun,  
New Territories

Yuen Long Home Affairs Enquiry Centre,  
Ground Floor, Yuen Long District Office Building,  
269 Castle Peak Road, Yuen Long,  
New Territories

District Lands Office, Tuen Mun,  
6th Floor, Tuen Mun Government Offices,  
No. 1 Tuen Hi Road, Tuen Mun,  
New Territories

District Lands Office, Yuen Long,  
9th Floor, Yuen Long Government Offices,  
2 Kiu Lok Square, Yuen Long,  
New Territories

*Opening Hours  
(except on public holidays)*

Monday to Friday  
9.00 a.m. to 7.00 p.m.

Monday to Friday  
8.45 a.m. to 12.30 p.m.  
and  
1.30 p.m. to 5.30 p.m.

30 May 2024

CHIU Lee-lee, Lily *Deputy Director/Specialist, Lands Department*

## ROADS (WORKS, USE AND COMPENSATION) ORDINANCE (Chapter 370)

(Notice under section 14)

RESUMPTION OF LAND FOR  
PWP ITEM NOS. 7787CL (PART) AND 7829CL  
HUNG SHUI KIU/HA TSUEN NEW DEVELOPMENT AREA  
ADVANCE WORKS PHASE 3 AND STAGE 2 WORKS—  
SITE FORMATION AND ENGINEERING INFRASTRUCTURE

TAKE NOTICE that under powers delegated by the Chief Executive of the Hong Kong Special Administrative Region, the Deputy Director/Specialist, Lands Department has made an order under section 13(1) of the Roads (Works, Use and Compensation) Ordinance (Chapter 370) (hereinafter referred to as 'the Ordinance') directing that all those pieces or parcels of land in the New Territories more particularly described below:—

Lots Nos. 7 S.B (Portion), 7 RP (Portion), 8 (Portion), 9 RP (Portion), 10 (Portion), 11 (Portion), 12 (Portion), 13 S.A RP (Portion), 13 S.B ss.2 (Portion), 13 S.B ss.3 (Portion), 13 S.B ss.4 (Portion), 13 S.B RP, 14 RP (Portion), 15 S.C (Portion), 15 RP (Portion), 33 (Portion), 40 (Portion), 41 (Portion), 42, 43, 44 (Portion), 45 (Portion), 50 (Portion), 51 (Portion), 52 (Portion), 63 (Portion), 64 (Portion), 67 (Portion), 69 (Portion), 70 (Portion), 71 (Portion), 72 (Portion), 73 (Portion), 74 (Portion), 75 (Portion), 76 (Portion), 77 (Portion), 78 S.A (Portion), 102 (Portion), 103 RP (Portion), 104 RP, 106 (Portion), 107 S.A (Portion), 108 S.B (Portion), 111 (Portion), 112 (Portion), 114 (Portion), 115 (Portion), 242 (Portion), 243, 244 (Portion), 245 (Portion), 249 (Portion), 250 S.B (Portion), 251 (Portion), 351 S.B ss.1 (Portion), 351 S.B RP (Portion), 351 S.C ss.1 (Portion), 351 S.C RP (Portion), 351 S.D (Portion), 352 S.A ss.1 (Portion), 352 S.A ss.2 (Portion), 352 S.B RP, 352 S.C, 352 RP, 353 (Portion), 356 (Portion), 480 S.A RP (Portion), 480 RP (Portion), 481 (Portion), 482 (Portion), 483 (Portion), 519 RP (Portion), 522 (Portion), 523 (Portion), 525 RP (Portion), 534 (Portion), 535 S.E (Portion), 536 (Portion), 537, 538 (Portion), 539, 540 (Portion), 541, 542 (Portion), 544 (Portion), 587 (Portion), 604 RP (Portion), 605 (Portion), 606 (Portion), 607 (Portion), 608 RP (Portion), 609 RP (Portion), 610 (Portion), 617 (Portion), 619 (Portion), 620 (Portion), 622 (Portion), 623 (Portion), 634 (Portion), 635 (Portion), 636 S.B RP (Portion), 637 RP (Portion), 638 RP (Portion), 639 RP (Portion), 642 RP, 643 RP (Portion), 648 RP (Portion), 649 RP (Portion), 650 (Portion), 651 (Portion), 652 (Portion), 1162 S.C (Portion), 1162 RP (Portion), 1181 S.A, 1181 S.B (Portion), 1182 S.A, 1182 RP (Portion), 1184 (Portion), 1188 (Portion), 1190 S.A (Portion), 1190 S.B (Portion), 1190 S.C (Portion), 1190 RP (Portion), 1191 (Portion), 1192 (Portion), 1193, 1194, 1195 (Portion), 1196 (Portion), 1197 (Portion), 1202 (Portion), 1203 (Portion), 1204 (Portion), 1205, 1206 (Portion), 1207 (Portion), 1210 (Portion), 1211 RP (Portion), 1212 RP, 1218 (Portion), 1219 S.A, 1219 S.B, 1219 RP, 1236 S.A ss.1 S.A, 1236 S.A ss.1 RP (Portion), 1236 S.A ss.12 (Portion) [formerly known as 1236 S.A RP (Portion)], 1236 S.B (Portion), 1237 (Portion), 1241 RP (Portion), 1243 (Portion), 1249 (Portion), 1250 (Portion), 1252, 1263 (Portion), 1264 S.A (Portion), 1267 (Portion), 1268 (Portion), 1282, 1283 (Portion), 1308 RP (Portion), 1314 RP (Portion), 1315 RP (Portion), 1316 (Portion), 1317 RP, 1318 (Portion), 1320 (Portion), 1322 (Portion), 1326 (Portion), 1327 (Portion), 1329 (Portion), 1330 (Portion), 1331 (Portion), 1336 (Portion), 1337 RP (Portion), 1351 (Portion), 1353 (Portion), 1354 (Portion), 1355 (Portion), 1362 (Portion), 1363 (Portion), 1367 (Portion), 1368 (Portion), 1369 (Portion), 1370 (Portion), 1371 (Portion), 1372 (Portion), 1373 (Portion), 1374 (Portion), 1375 (Portion), 1376 (Portion), 1382 (Portion), 1383 (Portion), 1384 (Portion), 1385 (Portion), 1387 (Portion), 1388 (Portion), 1391 (Portion), 1392 (Portion), 1394 (Portion), 1395 (Portion), 1396 (Portion), 1397 (Portion), 1400 (Portion), 1404 (Portion), 1405 (Portion), 1406 (Portion), 1407 (Portion), 1408 (Portion), 1409 RP, 1410 (Portion), 1415 (Portion), 1416 (Portion), 1420 (Portion), 1421 (Portion), 1423 (Portion), 1424 (Portion), 1425 (Portion), 1428 (Portion), 1433 (Portion), 1436 (Portion), 1437 (Portion), 1438 (Portion), 1439 (Portion), 1440 (Portion), 1441 (Portion), 1442 (Portion), 1443 (Portion), 1449 (Portion), 1450 (Portion), 1454 RP (Portion), 1457 (Portion), 1458 (Portion), 1461 (Portion), 1467 (Portion), 1468 (Portion), 1469 (Portion), 1471 (Portion), 1472 (Portion), 1473 (Portion), 1486 (Portion), 1487 (Portion), 1488 (Portion), 1494 (Portion), 1495 (Portion), 1496 (Portion), 1497 RP, 1498 RP, 1499 RP (Portion), 1507 RP (Portion), 1508 (Portion), 1509 RP (Portion), 1510 RP (Portion), 1511 (Portion), 1518 (Portion), 1519 (Portion), 1520 (Portion), 1547 RP (Portion), 1548 S.A (Portion), 1548 S.B RP (Portion), 1553 (Portion), 1557 (Portion), 1562 RP (Portion), 1563 (Portion), 1564

(Portion), 1565 (Portion), 1568 (Portion), 1574 (Portion), 1575 (Portion), 1576 (Portion), 1577 (Portion), 1578 (Portion), 1580 (Portion), 1581 (Portion), 1582 (Portion), 1583 (Portion), 1584 RP (Portion), 1585 (Portion), 1586 (Portion), 1587 (Portion), 1588 (Portion), 1589 (Portion), 1591 (Portion), 1592 (Portion), 1600 (Portion), 1601, 1602 (Portion), 1603 (Portion), 1604 (Portion), 1605 (Portion), 1606 (Portion), 1607 (Portion), 1608 RP (Portion), 1614 RP (Portion), 1615 RP (Portion), 1616 RP (Portion), 1621 (Portion), 1622 (Portion), 1623 (Portion), 1624 (Portion), 1625 (Portion), 1626 RP (Portion), 1627 (Portion), 1629 RP (Portion), 1630 RP (Portion), 1631 RP (Portion), 1634 (Portion), 1635 S.A RP (Portion), 1635 RP (Portion), 1636 RP (Portion), 1637 RP (Portion), 1639 S.A (Portion), 1639 RP (Portion), 1640 RP (Portion), 1641 RP (Portion), 1643 (Portion), 1644 (Portion), 1645 (Portion), 1646 (Portion), 1647 (Portion), 1665 (Portion), 1673 RP (Portion), 1674, 1675 (Portion), 1676 (Portion), 1677 (Portion), 1678 (Portion), 1694 (Portion), 1695 (Portion), 1699 (Portion), 1701 (Portion), 1702 (Portion), 1703 (Portion), 1706 (Portion), 1707, 1708 RP, 1709 RP, 1710 RP (Portion), 1711 RP (Portion), 1712 RP (Portion), 1713 RP (Portion), 1714 RP, 1715 RP (Portion), 2033 (Portion), 2139, 2142, 2151 (Portion), 2152 (Portion), 2153 (Portion), 2154, 2155 (Portion), 2156 (Portion), 2157, 2158, 2159, 2160, 2161, 2162 (Portion), 2163, 2164 (Portion), 2165 (Portion), 2167 (Portion), 2168 (Portion), 2169 (Portion), 2170, 2171 (Portion), 2172 (Portion), 2181 (Portion), 2182 (Portion), 2183 (Portion), 2184 (Portion), 2186 (Portion), 2187 (Portion), 2201 (Portion), 2202 (Portion), 2203 (Portion), 2207 S.A ss.2 S.A ss.1 (Portion), 2207 S.A ss.2 S.A RP (Portion), 2207 S.A ss.5 (Portion), 2207 S.A ss.7 (Portion), 2207 S.A ss.8 (Portion), 2207 S.A RP (Portion), 2209 S.B ss.1 S.B (Portion), 2209 S.B ss.1 RP (Portion), 2213 RP (Portion), 2214 RP (Portion), 2937 RP (Portion), 2946 (Portion), 2947 (Portion), 2948 (Portion), 2949 S.A (Portion), 2949 S.B (Portion), 2950 (Portion), 2951 (Portion), 2953 S.A (Portion), 2953 S.B (Portion), 2953 RP (Portion), 2959 (Portion), 2960 (Portion), 2961 (Portion), 2972 RP (Portion), 2973 RP (Portion), 2984 RP (Portion), 2985 (Portion), 3090 (Portion), 3091 (Portion), 3092 (Portion), 3093 (Portion), 3094 (Portion), 3097 (Portion), 3099 (Portion), 3100 (Portion), 3101 (Portion), 3102 (Portion), 3113 (Portion), 3114 (Portion), 3115 (Portion), 3116 S.A (Portion), 3116 S.B (Portion), 3117 S.A (Portion), 3118 (Portion), 3119 (Portion), 3122 (Portion), 3123 (Portion), 3132 RP (Portion), 3133 RP (Portion), 3134 RP (Portion), 3136 RP (Portion), 3138 RP (Portion), 3139 (Portion), 3141 (Portion), 3152 (Portion), 3159 (Portion), 3160 (Portion), 3170 (Portion), 3171, 3172 (Portion), 3177 (Portion), 3178 (Portion), 3179 S.A, 3179 RP (Portion), 3180 RP (Portion), 3203 (Portion), 3204, 3205 RP (Portion), 3206 RP (Portion), 3225 RP (Portion), 3226 RP (Portion), 3228 RP (Portion), 3229, 3230, 3231 (Portion), 3232 (Portion), 3234 (Portion), 3235 (Portion), 3236 RP (Portion), 3237 (Portion), 3238 RP (Portion), 3242 RP (Portion), 3243 RP (Portion), 3244 (Portion), 3245 (Portion), 3246 (Portion), 3247 (Portion), 3248 (Portion), 3249 (Portion), 3250 (Portion), 3251 (Portion), 3252 (Portion), 3253 (Portion), 3254 (Portion), 3255 (Portion), 3256 (Portion), 3259 (Portion), 3260 (Portion), 3261 (Portion), 3262 (Portion), 3263 (Portion), 3264 (Portion), 3265 (Portion), 3266 (Portion), 3268 (Portion), 3270 (Portion), 3272 (Portion), 3273 (Portion), 3274 (Portion), 3275 RP (Portion), 3276 RP (Portion), 3285 RP (Portion), 3286 (Portion), 3289 (Portion), 3290, 3291, 3292, 3293, 3294, 3298, 3299 (Portion), 3300 (Portion), 3302 (Portion), 3303 (Portion), 3304 (Portion), 3305 (Portion), 3307 (Portion), 3310 RP (Portion), 3311 RP (Portion), 3312 RP (Portion), 3313 RP (Portion), 3314 RP (Portion), 3316 RP (Portion), 3318 (Portion), 3319 S.A (Portion), 3319 S.B (Portion), 3320, 3321 (Portion), 3322 (Portion), 3323 (Portion), 3324 (Portion), 3325 (Portion), 3327 (Portion), 3328 (Portion), 3329 (Portion), 3330 (Portion), 3331 (Portion), 3338 (Portion), 3339 (Portion), 3340 (Portion), 3342 (Portion), 3343 (Portion), 3345 (Portion), 3346 (Portion), 3347 (Portion), 3348 (Portion), 3349 (Portion), 3350 (Portion), 3351 RP, 3352 RP, 3370 (Portion), 3371 (Portion), 3373 (Portion), 3390 (Portion), 3391 (Portion), 3392 (Portion), 3394 (Portion), 3395 (Portion), 3396 (Portion), 3397, 3398, 3399 (Portion), 3400 (Portion), 3401 (Portion), 3408 (Portion), 3409 (Portion), 3410, 3411 (Portion), 3412, 3413, 3414 RP, 3415 (Portion), 3416 RP (Portion), 3419 (Portion), 3426 (Portion), 3427 (Portion), 3429 RP (Portion), 3430 RP (Portion), 3431 RP (Portion), 3432 RP (Portion), 3433 RP (Portion), 3437 (Portion), 3440 (Portion), 3441 RP (Portion), 3442 RP (Portion), 3443 RP (Portion), 3444 (Portion), 3445 (Portion), 3446 (Portion), 3447 S.A, 3447 RP (Portion), 3448 (Portion), 3449 (Portion), 3450 (Portion), 3452 (Portion), 3453 (Portion), 3454 (Portion), 3460 RP (Portion), 3471 (Portion), 3472 (Portion), 3473, 3474, 3475, 3476, 3477, 3478, 3479, 3480, 3481 (Portion), 3482 (Portion), 3483 (Portion), 3499 (Portion), 3517 RP (Portion), 3519 (Portion), 3520 (Portion), 3521 (Portion), 3522 RP (Portion), 3523 (Portion), 3524 RP (Portion), 3527 RP (Portion), 3528 RP (Portion), 3529 RP (Portion), 3530 (Portion), 3531 (Portion), 3534 (Portion), 3535 (Portion), 3536 (Portion), 3537 (Portion), 3538 (Portion), 3539 (Portion), 3540 (Portion), 3544 (Portion), 3545 (Portion), 3546 (Portion), 3547, 3548, 3549 (Portion), 3550, 3551, 3552 (Portion), 3553 (Portion), 3554 (Portion), 3556 (Portion),

3557 (Portion), 3558 (Portion), 3561 RP (Portion), 3562, 3563 (Portion), 3595 (Portion), 3598 (Portion), 3599 (Portion), 3600, 3601 (Portion), 3602, 3603 (Portion), 3604 (Portion), 3605 (Portion), 3606, 3607, 3608 (Portion), 3609 (Portion), 3614 (Portion), 3615 (Portion), 3616 (Portion), 3617, 3618, 3619 (Portion), 3620 (Portion), 3621 (Portion), 3622 (Portion), 3624 (Portion), 3627 (Portion), 3628 (Portion), 3934 RP (Portion), 3936 (Portion), 3938 (Portion) and 3939 all in **Demarcation District No. 124;**

Lots Nos. 9 (Portion), 15 (Portion), 19 (Portion), 20 (Portion), 21 (Portion), 23 S.A (Portion), 23 RP (Portion), 24 (Portion), 25 (Portion), 27 (Portion), 29 (Portion), 32 S.A (Portion), 32 S.B (Portion), 36 (Portion), 40 S.C, 40 RP, 41, 42 (Portion), 43 (Portion), 44 S.B (Portion), 50 (Portion), 51 (Portion), 52 (Portion), 95 RP (Portion), 100 (Portion), 109 (Portion), 111, 112 (Portion), 115 RP, 147 (Portion), 169 (Portion), 172 (Portion), 173 (Portion), 174, 175 (Portion), 176 (Portion), 177 (Portion), 178 (Portion), 179 (Portion), 180 S.A (Portion), 180 S.B (Portion), 181 (Portion), 182 (Portion), 183 (Portion), 184 (Portion), 185 (Portion), 186 (Portion), 187 (Portion), 191 (Portion), 192 S.A (Portion), 192 S.B (Portion), 193, 197 (Portion), 199 (Portion), 200 (Portion), 201 (Portion), 202 (Portion), 203 (Portion), 204 (Portion), 206 (Portion), 219 (Portion), 220 (Portion), 222 (Portion), 223 (Portion), 227 (Portion), 232 (Portion), 236 (Portion), 238 (Portion), 239 (Portion), 240 (Portion), 241 (Portion), 242, 243, 244 (Portion), 245, 246 (Portion), 247, 248, 249, 250 (Portion), 251 (Portion), 252 (Portion), 255 (Portion), 256 (Portion), 269 (Portion), 270 (Portion), 272 (Portion), 273 (Portion), 274 (Portion), 275 (Portion), 276 (Portion), 277 (Portion), 278 (Portion), 279 (Portion), 280 (Portion), 281 (Portion), 282 (Portion), 283, 284, 285 (Portion), 313 (Portion), 314 (Portion), 315, 316 (Portion), 317 (Portion), 318 (Portion), 319 (Portion), 320 (Portion), 322 (Portion), 323 (Portion), 324 (Portion), 325 (Portion), 326 (Portion), 328, 329, 330, 331, 332, 333 (Portion), 334 RP (Portion), 335, 336 (Portion), 337, 338, 339, 340, 341, 342, 344 S.A, 344 RP, 345, 346, 347 (Portion), 349 (Portion), 353 (Portion), 360 (Portion), 361 (Portion), 362 (Portion), 363 (Portion), 365 (Portion), 366 (Portion), 367, 368 (Portion), 369 (Portion), 370 S.A (Portion), 370 S.B (Portion), 371 (Portion), 372 (Portion), 373 (Portion), 374 (Portion), 375 (Portion), 388 RP (Portion), 389 RP (Portion), 390 (Portion), 391 (Portion), 392 (Portion), 393, 394 (Portion), 395 (Portion), 396 (Portion), 399 RP (Portion), 401 (Portion), 402, 403 RP, 404 RP, 406 RP, 429 RP, 430 RP (Portion), 431 RP (Portion), 432 RP (Portion), 439 (Portion), 536 (Portion), 537, 538 (Portion), 539 (Portion), 541 (Portion), 545 (Portion), 546 S.A (Portion), 547 (Portion), 554 (Portion), 556 (Portion), 572 (Portion), 573 (Portion), 574 (Portion), 575 (Portion), 576 (Portion), 577 (Portion), 578 (Portion), 579 (Portion), 699 (Portion), 704 (Portion), 705 (Portion), 717 (Portion), 719 (Portion), 720 (Portion), 721 (Portion), 727 (Portion), 728 (Portion), 729 (Portion), 730 (Portion), 731 (Portion), 733 (Portion), 734 (Portion), 736 (Portion), 737 (Portion), 756 (Portion), 757 (Portion), 758 (Portion), 759 (Portion), 760 (Portion), 766 (Portion), 767, 768 (Portion), 770 S.B (Portion), 817 S.A RP (Portion), 817 S.B RP (Portion), 1100 RP (Portion), 1101 RP (Portion), 1102 RP (Portion), 1103 RP (Portion), 1104 RP (Portion), 1105 (Portion), 1107 (Portion), 1132 (Portion), 1138 (Portion), 1139 S.A RP (Portion), 1139 RP (Portion), 1140 (Portion), 1141 RP (Portion), 1144 S.D (Portion), 1144 S.E, 1144 S.F (Portion), 1144 RP (Portion), 1145 (Portion), 1146 (Portion), 1147 (Portion), 1149 (Portion), 1151 (Portion), 1152 (Portion), 1159 (Portion), 1160 (Portion), 1161 (Portion), 1176 RP (Portion), 1187 RP (Portion), 1188 RP (Portion), 1189 RP (Portion), 1191 (Portion), 1192 (Portion), 1195 (Portion), 1197 (Portion), 1198 (Portion), 1199 S.A, 1199 S.B (Portion), 1200 (Portion), 1201 (Portion), 1202 S.A, 1202 S.B (Portion), 1203 (Portion), 1204, 1205 (Portion), 1206 (Portion), 1207 (Portion), 1208 (Portion), 1213 (Portion), 1214 (Portion), 1215 (Portion), 1220 (Portion), 1221 (Portion), 1222 (Portion), 1228 (Portion), 1229 RP (Portion), 1231 RP (Portion), 1236 (Portion), 1237 (Portion), 1238 (Portion), 1243 RP (Portion), 1244 RP (Portion), 1245 RP, 1256 RP (Portion), 1276 RP (Portion), 1279 (Portion), 1294 (Portion), 1295 RP (Portion), 1304 (Portion), 1305 RP (Portion), 1306 RP (Portion), 1307 RP (Portion), 1308 (Portion), 1309 (Portion), 1311 (Portion), 1312, 1313 (Portion), 1314 (Portion), 1315 (Portion), 1317 S.A, 1317 RP, 1318, 1319 S.A RP (Portion), 1319 S.B, 1319 S.C, 1321 RP, 1322 RP, 1324 RP (Portion), 1325 RP (Portion), 1326 RP (Portion), 1334 (Portion), 1335 (Portion), 1448 RP (Portion), 1450 RP, 1451 RP (Portion), 1452 RP (Portion), 1453 (Portion), 1454 RP (Portion), 1457 RP (Portion), 1458 RP (Portion), 1459 RP (Portion), 1474 (Portion), 1475 RP (Portion), 1476 RP (Portion), 1477 (Portion), 1479 RP (Portion), 1480 RP (Portion), 1481 S.B RP (Portion), 1482 RP (Portion), 1484 RP (Portion), 1486 RP (Portion), 1488 RP (Portion), 1489 RP (Portion), 1490 RP, 1491 RP (Portion), 1492 RP (Portion), 1493 (Portion), **1498 S.A ss.2 (Portion)**, 1498 S.A RP (Portion), **1498 S.B RP (Portion)**, 1499 RP (Portion), 1500 (Portion), 1501 RP (Portion), 1502 RP (Portion), 1503 RP (Portion), 1505 S.A (Portion), 1506 (Portion), 1508 RP (Portion), 1510 RP (Portion), 1511 RP (Portion),

1513 (Portion), 1527 RP (Portion), 1528 RP (Portion), 1529 RP (Portion), 1530 RP (Portion), 1531 (Portion), 1538 RP (Portion), 1539 (Portion), 1540 (Portion), 1541 RP (Portion), 1542 RP (Portion), 1543 (Portion), 1544 (Portion), 1546 (Portion), 1547 (Portion), 1549 (Portion), 1550 (Portion), 1551 (Portion), 1552 RP (Portion) [formerly known as 1552 S.C (Portion), 1552 S.D (Portion), 1552 S.E (Portion), 1552 S.F and 1552 RP (Portion)], 1553 (Portion), 1555 (Portion), 1556 S.B, 1556 RP (Portion), 1557 RP (Portion), 1558 S.B, 1558 RP (Portion), 1560 RP (Portion), 1593 (Portion), 1594 (Portion), 1596, 1597, 1598 RP (Portion), 1599 (Portion), 1600 (Portion), 1601 (Portion), 1602 (Portion), 1603 (Portion), 1604 S.A (Portion), 1604 RP (Portion), 1605 (Portion), 1606 (Portion), 1607 (Portion), 1608 S.A (Portion), 1608 S.B (Portion), 1609 (Portion), 1610 (Portion), 1667 S.B RP (Portion), 1668 S.B RP, 1670 RP (Portion), 1671 S.B RP (Portion), 1672 S.B RP, 1673 RP, 1674 RP (Portion), 1675, 1676 RP (Portion), 1677 S.A, 1677 S.B (Portion), 1682 (Portion), 1683 (Portion), 1684 S.A (Portion), 1684 S.B (Portion), 1685 (Portion), 1687 (Portion), 1743 RP (Portion), 1744 S.K (Portion), 1744 RP (Portion), 1745 (Portion), 1747, 1748 (Portion), 1749 (Portion), 1750 (Portion), 1751 (Portion), 1752 (Portion), 1753 (Portion), 1754 (Portion), 1756 (Portion), 1757 RP (Portion), 1758 RP (Portion), 1759 (Portion), 1967 S.B RP (Portion), 1969 (Portion), 1974 (Portion), 1975 RP (Portion), 1976 RP (Portion), 1977 (Portion), 1980 RP (Portion), 1998 RP (Portion), 1999 (Portion), 2000, 2001 (Portion), 2002 (Portion) and 2003 (Portion) all in **Demarcation District No. 125;**

Lot No. 26 S.B RP (Portion) in Demarcation District No. 127; and

Lots Nos. 1674 RP (Portion), 1689, 1690 (Portion), 1691 (Portion), 1693 (Portion), 1694 (Portion), 1695 (Portion), 1696 (Portion), 1702 RP, 1703 (Portion), 1704 (Portion), 1707 (Portion), 1709 RP (Portion), 1711 RP (Portion), 1717 RP, 1719 RP (Portion), 1720 RP (Portion), 1721 RP (Portion), 1722 RP (Portion), 1724 RP (Portion), 1733 (Portion), 1734 (Portion), 1735 (Portion), 1736 RP (Portion), 1738 RP (Portion), 1739 RP (Portion), 1740 RP (Portion), 1742 (Portion), 1745 (Portion), 1746 (Portion), 1747 (Portion), 1748 (Portion), 1749 (Portion), 1750 (Portion), 1751 (Portion), 1752 (Portion), 1753 (Portion), 1754 (Portion), 1755 (Portion), 1756 (Portion), 1757 RP, 1758, 1759 (Portion), 1760, 1761 (Portion), 1762 RP (Portion), 1764 RP (Portion), 1765 RP (Portion), 1766 S.C (Portion), 1766 S.D RP (Portion), 1766 S.F RP (Portion), 1766 RP (Portion), 1767 RP (Portion), 1768 RP (Portion), 1769 RP, 1772 RP (Portion), 1773, 1774 (Portion), 1775 (Portion), 1776 (Portion), 1778, 1779 S.A ss.1, 1779 S.A RP (Portion), 1779 S.B ss.1 (Portion), 1779 S.B RP (Portion), 1779 S.C (Portion), 1779 RP (Portion), 1780, 1781 (Portion), 1782, 1783, 1784 (Portion), 1785 (Portion), 1803 RP (Portion), 1804 RP (Portion), 1808 (Portion), 1810 RP (Portion), 1813 RP (Portion), 1817 RP (Portion), 1820 RP (Portion), 1824 RP (Portion), 1825 S.A (Portion), 1825 S.B, 1825 RP (Portion), 1829 RP, 1830, 1831, 1832 (Portion), 1833 (Portion), 1835 (Portion), 1836 (Portion), 1839 (Portion), 1840 RP (Portion), 1841 RP (Portion), 1846 (Portion), 1847 (Portion), 1849 RP (Portion), 1850 RP (Portion), 1856 (Portion), 1862 (Portion), 1864 RP (Portion), 1865 RP (Portion), 1866 RP (Portion), 1875 (Portion), 1876 S.A, 1876 RP (Portion), 1877 (Portion), 1881 (Portion), 1883 RP (Portion), 1889 RP, 1892 (Portion), 1893, 1894 (Portion), 1895 RP (Portion), 1914 (Portion), 1918 (Portion), 1925 (Portion), 1927 (Portion), 1930 RP (Portion), 1931 (Portion), 1932 RP (Portion), 1935 (Portion), 1936 (Portion), 1937 (Portion), 1938 (Portion), 1939 (Portion), 1940 S.A (Portion), 1940 RP, 1941 S.A (Portion), 1941 RP (Portion), 1942 (Portion), 1948 (Portion), 1949 (Portion), 1950 (Portion), 1951 (Portion), 1952 (Portion), 1953 (Portion), 1954 (Portion), 1958 RP, 2045 RP (Portion), 2053 S.B RP (Portion), 2061 S.B RP, 2062 S.B RP, 2063 S.B RP (Portion), 2114 (Portion), 2115 (Portion), 2116 (Portion), 2117 (Portion), 2119 (Portion), 2120 (Portion), 2128 (Portion), 2129 (Portion), 2143 (Portion), 2144 RP (Portion), 2173 (Portion), 2175 S.A (Portion), 2176 (Portion), 2177 (Portion), 2178, 2179 (Portion), 2180 (Portion), 2181 (Portion), 2185 (Portion), 2186 (Portion), 2187 (Portion), 2188 (Portion), 2189 (Portion), 2190 (Portion) and 2191 S.B (Portion) all in Demarcation District No. 130

and shown coloured orange on the Resumption Plan No. YLM10744 and Modification Resumption Plans Nos. YLM11095 and YLM11155 and also the land shown coloured orange stippled black on the Resumption Plan No. YLM10744 annexed to the said order, which land was described in the scheme referred to in Government Notice No. 5387 published on 30 September 2022 and 7 October 2022 and as modified by Government Notice No. 272 published on 19 January 2024 and 26 January 2024, shall be resumed.

The electronic version of this notice and the aforesaid Resumption Plan and Modification Resumption Plans may be viewed on the Lands Department website (<https://www.landsd.gov.hk/en/resources/gov-notices/acq.html>) under Government Notices after this notice is published in the

*Gazette*. A copy of the said order, a copy of this notice, and the aforesaid Resumption Plan and Modification Resumption Plans may be inspected by members of the public, free of charge, at the following offices during the following hours when those offices are normally open to the public:—

<i>Offices</i>	<i>Opening Hours (except on public holidays)</i>
Central and Western Home Affairs Enquiry Centre, Ground Floor, Harbour Building, 38 Pier Road, Central, Hong Kong	Monday to Friday 9.00 a.m. to 7.00 p.m.
Tuen Mun Home Affairs Enquiry Centre, 2nd Floor, Tuen Mun Government Offices, No. 1 Tuen Hi Road, Tuen Mun, New Territories	
Yuen Long Home Affairs Enquiry Centre, Ground Floor, Yuen Long District Office Building, 269 Castle Peak Road, Yuen Long, New Territories	
District Lands Office, Tuen Mun, 6th Floor, Tuen Mun Government Offices, No. 1 Tuen Hi Road, Tuen Mun, New Territories	Monday to Friday 8.45 a.m. to 12.30 p.m. and 1.30 p.m. to 5.30 p.m.
District Lands Office, Yuen Long, 9th Floor, Yuen Long Government Offices, 2 Kiu Lok Square, Yuen Long, New Territories	

This notice was affixed on or near the said land on 30 May 2024.

The Deputy Director/Specialist, Lands Department has under section 13(2) of the Ordinance specified a period of notice of THREE MONTHS from the date upon which this notice was affixed on or near the said land.

It is hereby declared that upon expiry of that period at midnight on 30 August 2024, the land described above shall by virtue of section 13(3) of the Ordinance revert to the Government of the Hong Kong Special Administrative Region for the purposes of or incidental to the works or the use described in the said scheme. The date of reversion shall be 31 August 2024.

Any person entitled to compensation under the Ordinance may serve upon the Secretary for Transport and Logistics a written claim, which can be submitted *via* one of the following means, before the expiration of one year from the date of resumption:—

- (1) By post or by hand to the Transport and Logistics Bureau's Drop-in Box No. 6 located at the 2nd Floor Entrance, East Wing, Central Government Offices, 2 Tim Mei Avenue, Tamar, Hong Kong. The box is available for use between 8.00 a.m. and 7.00 p.m. from Monday to Friday (except public holidays);
- (2) By fax to (852) 2868 4643; or
- (3) By email to [gazettetlb@tlb.gov.hk](mailto:gazettetlb@tlb.gov.hk).

Personal Information Collection Statement

Any information, including the personal data, submitted to the Secretary for Transport and Logistics in connection with any written claims served under section 29 of the Roads (Works, Use and Compensation) Ordinance (Chapter 370) will be used for the processing of the claims and other related purposes. The provision of the information, including the personal data, as required under section 29 of the Roads (Works, Use and Compensation) Ordinance (Chapter 370) is obligatory. If such information, including the personal data, as required under section 29 of the Roads (Works, Use and Compensation) Ordinance (Chapter 370) is not provided as requested, the claims may be rejected. Any information, including the personal data, so submitted may be disclosed to the relevant government departments and other organizations or agencies which are required to handle the claims and related matters. Persons who have so submitted their personal data have the rights to request access to and correction of their personal data in relation to their claims. Request for access to or correction of the personal data should be made in writing to the Personal Data Privacy Officer of the Transport and Logistics Bureau at 20th Floor, East Wing, Central Government Offices, 2 Tim Mei Avenue, Tamar, Hong Kong.

## **Appendix C**

### **Alternative Site and Suitability for Relocation of the Applicant's Affected Business in HSK/HT NDA**

**Appendix C – Alternative Site and Suitability for Relocation of the Applicant’s Affected Business in HSK/HT NDA**

<b>Alternative Site/ Application Site</b>	<b>Site 1</b>	<b>Site 2</b>	<b>Site 3</b>	<b>Site 4</b>	<b>Application Site</b>
Location	Lot 1885 RP in D.D. 105, Mai Po Lo Wai, Mai Po, Yuen Long	Lots 777 and 969 in D.D. 78, Ta Kwu Ling	Lots 3335 S.BN, 3335 S.O RP, 3339 RP, 3340 RP, 3341 RP, 3345 RP, 3346 RP, 3347, 3348, 3349, 3350 S.B RP in D.D. 91, Lots 1486RP, 1488, 1490, 1491, 1493RP, 1494 S.B RP in D.D. 100, Lin Tong Mei (North), Fanling, N.T.	Lots 645 (Part), 647, 650 S.A, 650 S.B (Part), 651 (Part), 653 (Part) and 654 (Part) in D.D. 82, Ta Kwu Ling, New Territories	Lots 1212 (Part), 1213, 1214, 1215, 1216, 1447 (Part), 1448 (Part), 1477 S.A (Part), 1478 RP (Part) in D.D.106 and Adjoining Government Land, Kam Tin, Yuen Long, New Territories
Site Area	16,572 m <sup>2</sup> (about)	9,689 m <sup>2</sup> (about)	16,000 m <sup>2</sup> (about)	5,913 m <sup>2</sup> (about)	About 16,076m <sup>2</sup>
Outline Zoning Plan (OZP)	Draft Mai Po and Fairview Park OZP No. S/YL-MP/9	Approved Ta Kwu Ling North OZP No. S/NE-TKLN/2	Approved Kwu Tung South OZP No. S/NE-KTS/22	Approved Ping Che and Ta Kwu Ling OZP No. S/NE-TKL/746	Approved Kam Tin South OZP No. S/YL-KTS/15
Zoning	“Village Type Development” (“V”)	“Agriculture” (“AGR”)	“Agriculture” (“AGR”)	“Agriculture” (“AGR”)	“Agriculture”
Accessibility	Accessible from Castle Peak Road via local access	Accessible from Lin Chuk Road	Local access via Fan Kam Road	Local access via Ping Che Road	Accessible from Kam Sheung Road
Existing Condition	Abandoned fish pond covered by vegetation	Partially covered with vegetation and an access road passing through the lots	Partly covered by tree groups and vegetation and partly paved	Partly covered by tree groups and vegetation and partly hard paved with asphalt	Partly fenced-off , covered with shrubs and weeds
Surrounding Area	Surrounded by village houses, ponds and a site with Special Scientific Interest	Surrounded by vegetation and brownfield operations	Surrounded by tree groups and village houses with a “Green Belt” zone located to its north	Surrounded by tree groups, water stream, village houses	Surrounded by village houses, agricultural land, brownfield operations and vacant land

<b>Alternative Site/ Application Site</b>	<b>Site 1</b>	<b>Site 2</b>	<b>Site 3</b>	<b>Site 4</b>	<b>Application Site</b>
Previous Application at the Sites	Yes	Yes	Yes	Yes	Yes
Similar Application at the Same Land Use Zoning	No	No	No	Yes	Yes

*S.16 Planning Application for Proposed Temporary Warehouse (Excluding Dangerous Goods Godown) with Ancillary Facilities and Associated Filling of Land for a Period of 3 Years in "Agriculture" Zone, Lots 1212 (Part), 1213, 1214, 1215, 1216, 1447 (Part), 1448 (Part), 1477 S.A (Part), 1478 RP (Part) in D.D. 106 and adjoining Government Land, Kam Tin, Yuen Long, New Territories*

*Planning Statement*

---

## **Appendix D**

### **Drainage Proposal**

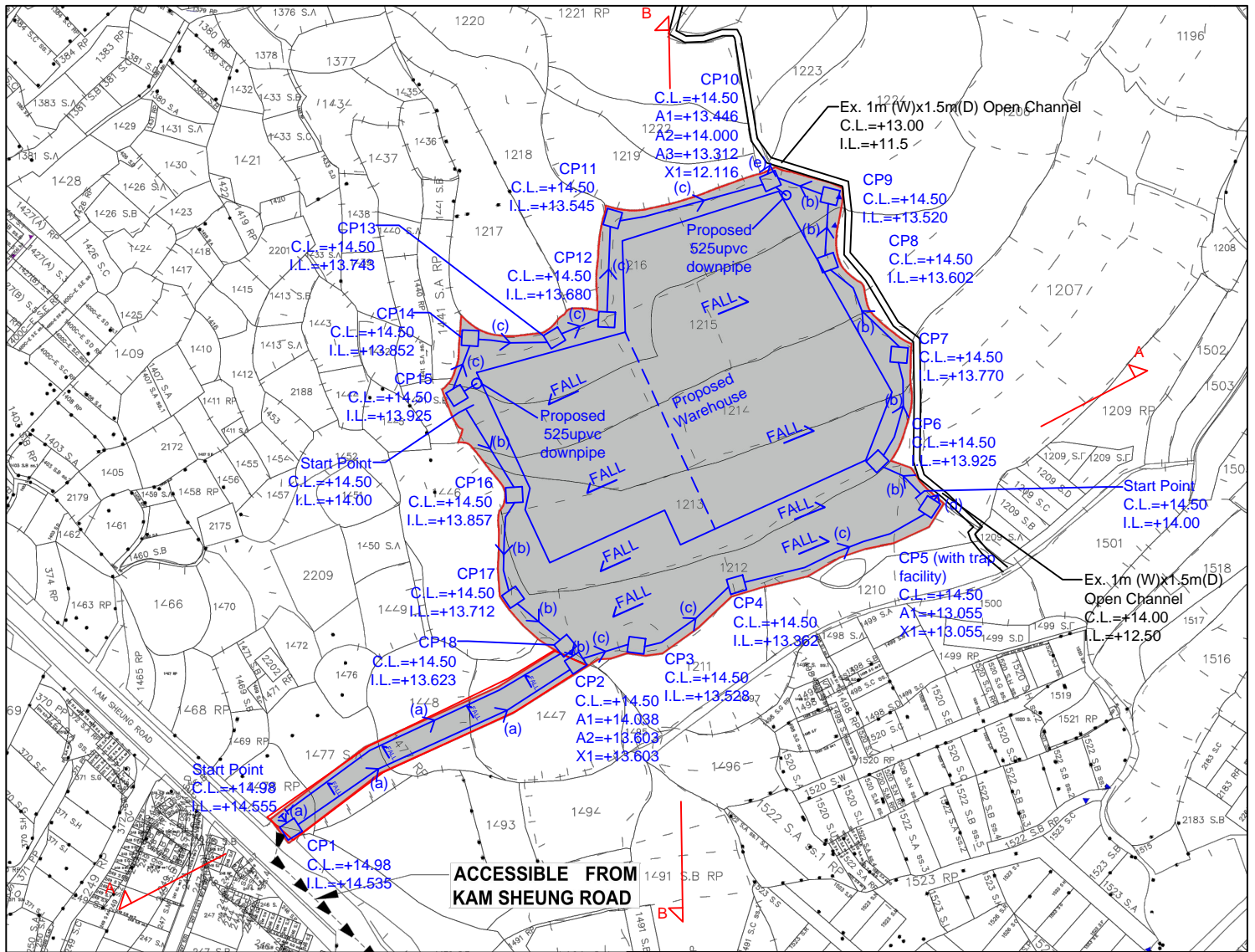

- Note:**
- Catchpits (CP5 & CP10) with desilting facility shall follow CEDD standard drawing No. C24061.
  - Catchpit and UC follows Typical Details of Geotechnical Manual for Slope Fig.8.10 and Fig.8.11 respectively.
  - Fence Wall to be erected (if any) shall be Open-bottom type.
  - Maximum 900mm filling.

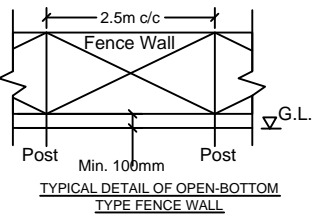

**LEGEND**

- Existing Catchpit
- Ex. 1m(W)x1.5m(D) Open Channel
- Proposed CatchPit
- Proposed 375UC (1:200) with Cast Iron Cover
- Proposed 450UC (1:200) with Cast Iron Cover
- Proposed 525UC (1:200) with Cast Iron Cover
- Proposed 525mm dia. concrete pipe (1:100)
- Proposed 600mm dia. concrete pipe (1:125)
- Proposed 525upvc downpipe

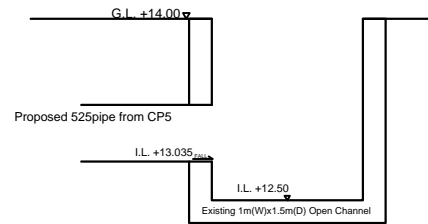
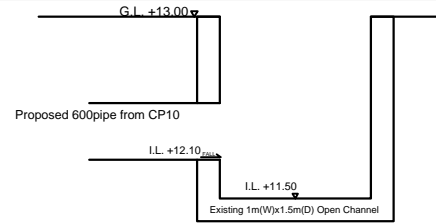

正宏工程顧問公司

CHING WAN ENGINEERING CONSULTANT COMPANY

**Project:**  
**PROPOSED TEMPORARY WAREHOUSE (EXCLUDING DANGEROUS GOODS GODOWN) WITH ANCILLARY FACILITIES AND ASSOCIATED FILLING OF LAND FOR A PERIOD OF 3 YEARS at VARIOUS LOTS IN D.D. 106 AND ADJOINING GOVERNMENT LAND, KAM TIN, YUEN LONG, NEW TERRITORIES**  
 (Application Number: )

Title: Drainage Proposal - LAYOUT		D01-1
Drawn by: DM	Date: 23-4-2026	
Check by: DM	Scale: ----	

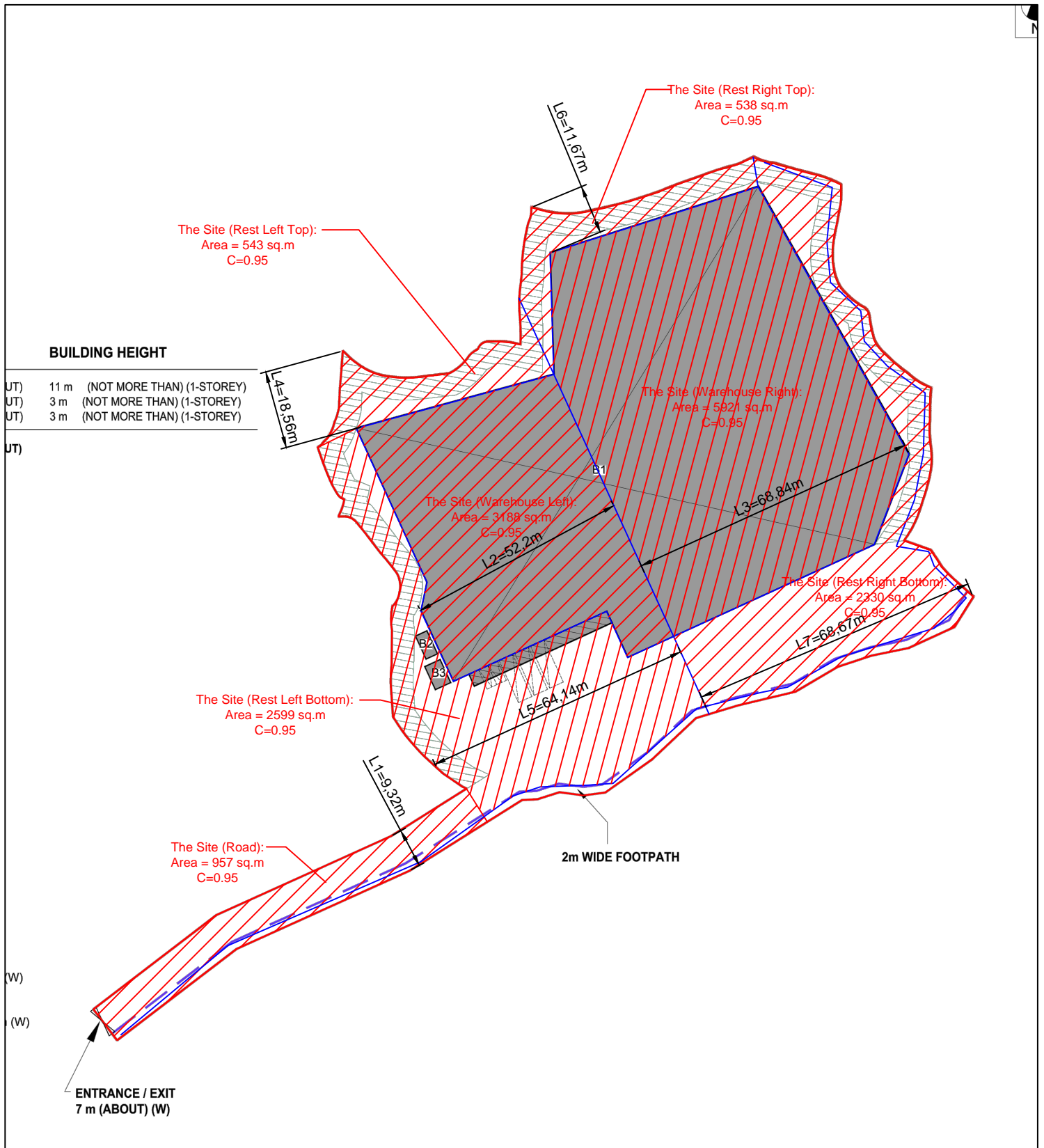

正宏工程顧問公司

CHING WAN ENGINEERING CONSULTANT COMPANY

**Project:**  
**PROPOSED TEMPORARY WAREHOUSE (EXCLUDING DANGEROUS GOODS GODOWN) WITH ANCILLARY FACILITIES AND ASSOCIATED FILLING OF LAND FOR A PERIOD OF 3 YEARS at VARIOUS LOTS IN D.D. 106 AND ADJOINING GOVERNMENT LAND, KAM TIN, YUEN LONG, NEW TERRITORIES**  
 (Application Number: )

Title:

Drainage Proposal -  
 CATCHMENT AREA PLAN

D02

Drawn by:

DM

Date:

17-4-2026

Check by:

DM

Scale:

----

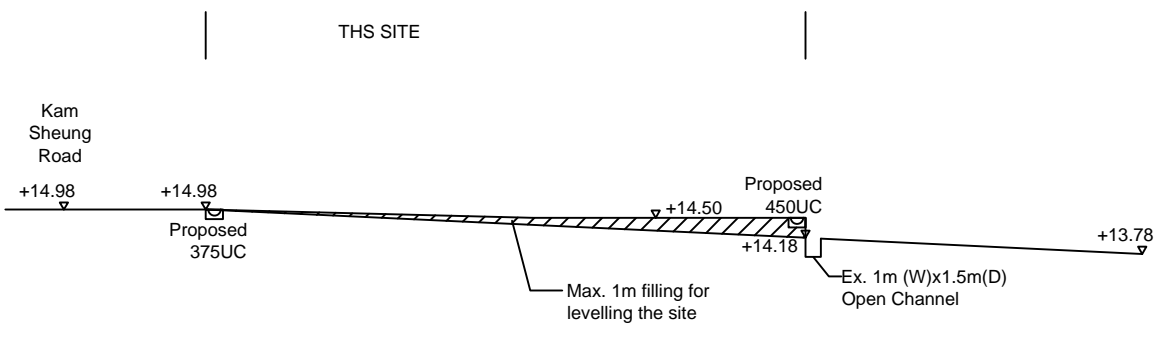

SECTION A-A

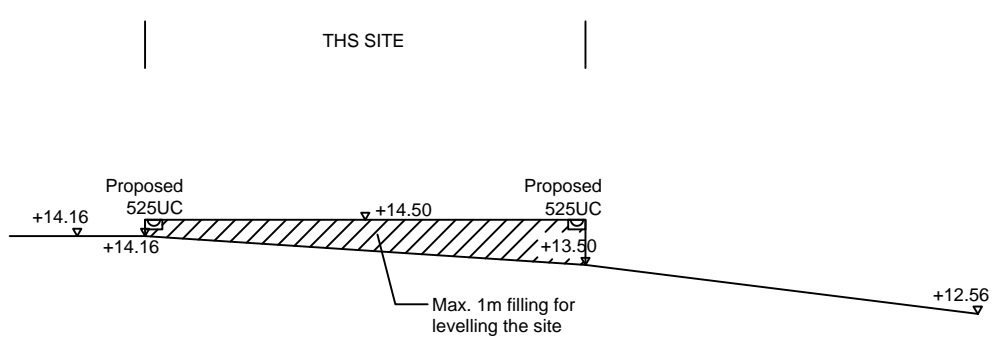

SECTION B-B

正宏工程顧問公司

CHING WAN ENGINEERING CONSULTANT COMPANY

Title:

Drainage Proposal -  
SECTIONS

D03

Drawn by:

DM

Date:

23-4-2026

Project:

**PROPOSED TEMPORARY WAREHOUSE (EXCLUDING DANGEROUS GOODS GODOWN) WITH ANCILLARY FACILITIES AND ASSOCIATED FILLING OF LAND FOR A PERIOD OF 3 YEARS at VARIOUS LOTS IN D.D. 106 AND ADJOINING GOVERNMENT LAND, KAM TIN, YUEN LONG, NEW TERRITORIES**  
(Application Number: )

Check by:

DM

Scale:

----

Road	= 957	m <sup>2</sup>	(C= 0.95 )	L1= 5	m
Warehouse left	= 3188	m <sup>2</sup>	(C= 0.95 )	L2= 52.2	m
warehouse right	= 5921	m <sup>2</sup>	(C= 0.95 )	L3= 68.84	m
Rest Left Top	= 543	m <sup>2</sup>	(C= 0.95 )	L4= 18.56	m
Rest Left Bottom	= 2599	m <sup>2</sup>	(C= 0.95 )	L5= 64.14	m
Rest Right Top	= 538	m <sup>2</sup>	(C= 0.95 )	L6= 11.67	m
Rest Right Bottom	= 2330	m <sup>2</sup>	(C= 0.95 )	L7= 68.67	m

**Calculation of Design Runoff of the Proposed Development.**

**For the design of drains from Start Point to CP2 and Start Point to CP18, Consider Road**

$$\Sigma Q = \Sigma 0.278 C i A$$

$$A = 957 \text{ m}^2$$

$$= 957 \text{ m}^2$$

$$= 0.000957 \text{ km}^2$$

$$t = 0.14465 L1/ H^{0.2} A^{0.1}$$

$$= 0.14465 * 5 / 1^{0.2} * 957^{0.1}$$

$$= 0.364 \text{ min}$$

$$i = 1.16 * a / (t+b)^c \quad (50 \text{ yrs return period, Table 3a, Corrigendum 2024, SDM) and (16\% increase due to climate change)}$$

$$= 1.16 * 505.5 / (0.364 + 3.29)^{0.355}$$

$$= 370.2 \text{ mm/hr}$$

Therefore, Q1 =  $0.278 * 0.95 * 370.2 * 0.000957 / 0.9$  (0.9 factor is adopted for sedimentation)

$$= 0.1040 \text{ m}^3/\text{sec}$$

$$= \mathbf{6237} \text{ lit/min}$$

**Provide 375UC (1:200) is OK**

**For the design of drains from Start Point to CP18 via CP16, Consider Rest Left Bottom**

$$\Sigma Q = \Sigma 0.278 C i A$$

$$A = 2599 \text{ m}^2$$

$$= 2599 \text{ m}^2$$

$$= 0.002599 \text{ km}^2$$

$$t = 0.14465 L5/ H^{0.2} A^{0.1}$$

$$= 0.14465 * 64.14 / 1^{0.2} * 2599^{0.1}$$

$$= 4.226 \text{ min}$$

$$i = 1.16 * a / (t+b)^c \quad (50 \text{ yrs return period, Table 3a, Corrigendum 2024, SDM) and (16\% increase due to climate change)}$$

$$= 1.16 * 505.5 / (4.226 + 3.29)^{0.355}$$

$$= 286.5 \text{ mm/hr}$$

Therefore, Q2 =  $0.278 * 0.95 * 286.5 * 0.002599 / 0.9$  (0.9 factor is adopted for sedimentation)

$$= 0.2185 \text{ m}^3/\text{sec}$$

$$= \mathbf{13112} \text{ lit/min}$$

**Provide 450UC (1:200) is OK**

**For the design of drains from CP2 to CP5 and outfall from CP5, Q1+Q2**

$$\begin{aligned} Q3 &= Q1 + Q2 \\ &= 6237 + 13112 \\ &= \mathbf{19349} \quad \text{lit/min} \end{aligned}$$

**Provide 525UC (1:200) and 525mm dia. concrete pipe (1:100) is OK**

**For the design of drains from CP15 to CP12, Consider Warehouse Left + Rest Left Top**

$$\Sigma Q = \Sigma 0.278 C i A$$

$$\begin{aligned} A &= 3188+543 \quad \text{m}^2 \\ &= 3731 \\ &= 0.003731 \quad \text{km}^2 \end{aligned}$$

$$\begin{aligned} t &= 0.14465 L/2 H^{0.2} A^{0.1} \\ &= 0.14465 * 52.2 / 1^{0.2} * 3731^{0.1} \\ &= 3.317 \quad \text{min} \end{aligned}$$

$$\begin{aligned} i &= 1.16 * a / (t+b)^c \quad (50 \text{ yrs return period, Table 3a, Corrigendum 2024,} \\ &= 1.16 * 505.5 / (3.317 + 3.29)^{0.355} \quad \text{SDM) and (16\% increase due to climate change)} \\ &= 300.0 \quad \text{mm/hr} \end{aligned}$$

$$\begin{aligned} \text{Therefore, } Q4 &= 0.278 * 0.95 * 300.0 * 0.003731 / 0.9 \quad (0.9 \text{ factor is adopted for sedimentation)} \\ &= 0.3284 \quad \text{m}^3/\text{sec} \\ &= \mathbf{19705} \quad \text{lit/min} \end{aligned}$$

**Provide 525UC (1:200) is OK**

**For the design of drains from CP12 to CP10, Consider Q4 + Rest Right Top**

$$\Sigma Q = \Sigma 0.278 C i A$$

$$\begin{aligned} A &= 538 \quad \text{m}^2 \\ &= 538 \\ &= 0.000538 \quad \text{km}^2 \end{aligned}$$

$$\begin{aligned} t &= 0.14465 L/6 H^{0.2} A^{0.1} \\ &= 0.14465 * 11.67 / 1^{0.2} * 538^{0.1} \\ &= 0.900 \quad \text{min} \end{aligned}$$

$$\begin{aligned} i &= 1.16 * a / (t+b)^c \quad (50 \text{ yrs return period, Table 3a, Corrigendum 2024,} \\ &= 1.16 * 505.5 / (0.900 + 3.29)^{0.355} \quad \text{SDM) and (16\% increase due to climate change)} \\ &= 352.6 \quad \text{mm/hr} \end{aligned}$$

$$\begin{aligned} \text{Therefore, } Q5 &= 0.278 * 0.95 * 352.6 * 0.000538 / 0.9 + Q4 \quad (0.9 \text{ factor is adopted for sedimentation)} \\ &= 0.3841 \quad \text{m}^3/\text{sec} \\ &= \mathbf{23045} \quad \text{lit/min} \end{aligned}$$

**Provide 525UC (1:200) is OK**

**For the design of drains from Start Point to CP10 via CP6, Consider Rest Right Bottom**

$$\Sigma Q = \Sigma 0.278 C i A$$

$$\begin{aligned} A &= 2330 \quad \text{m}^2 \\ &= 2330 \\ &= 0.00233 \quad \text{km}^2 \end{aligned}$$

$$\begin{aligned} t &= 0.14465 L/7 H^{0.2} A^{0.1} \\ &= 0.14465 * 68.67 / 1^{0.2} * 2330^{0.1} \\ &= 4.575 \quad \text{min} \end{aligned}$$

$$\begin{aligned} i &= 1.16 * a / (t+b)^c \quad (50 \text{ yrs return period, Table 3a, Corrigendum 2024,} \\ &= 1.16 * 505.5 / (4.575 + 3.29)^{0.355} \quad \text{SDM) and (16\% increase due to climate change)} \\ &= 282.0 \quad \text{mm/hr} \end{aligned}$$

$$\begin{aligned} \text{Therefore, } Q6 &= 0.278 * 0.95 * 282.0 * 0.00233 / 0.9 \quad (0.9 \text{ factor is adopted for sedimentation)} \\ &= 0.1928 \quad \text{m}^3/\text{sec} \\ &= \mathbf{11568} \quad \text{lit/min} \end{aligned}$$

**Provide 450UC (1:200) is OK**

**For the design of drains of outfall from CP10.**

$$\begin{aligned} Q3 &= Q5 + Q6 \\ &= 23045 + 11568 \\ &= \mathbf{34612} \quad \text{lit/min} \end{aligned}$$

**Provide 600mm dia. concrete pipe (1:125) is OK**

**GEO Technical Guidance Note No. 43 (TGN 43)**  
**Guidelines on Hydraulic Design of U-shaped and Half-round Channels on Slopes**

Issue No.: 1    Revision: -    Date: 05.06.2014    Page: 3 of 3

Figure 1 - Chart for the rapid design of U-shaped and half-round channels up to 600 mm

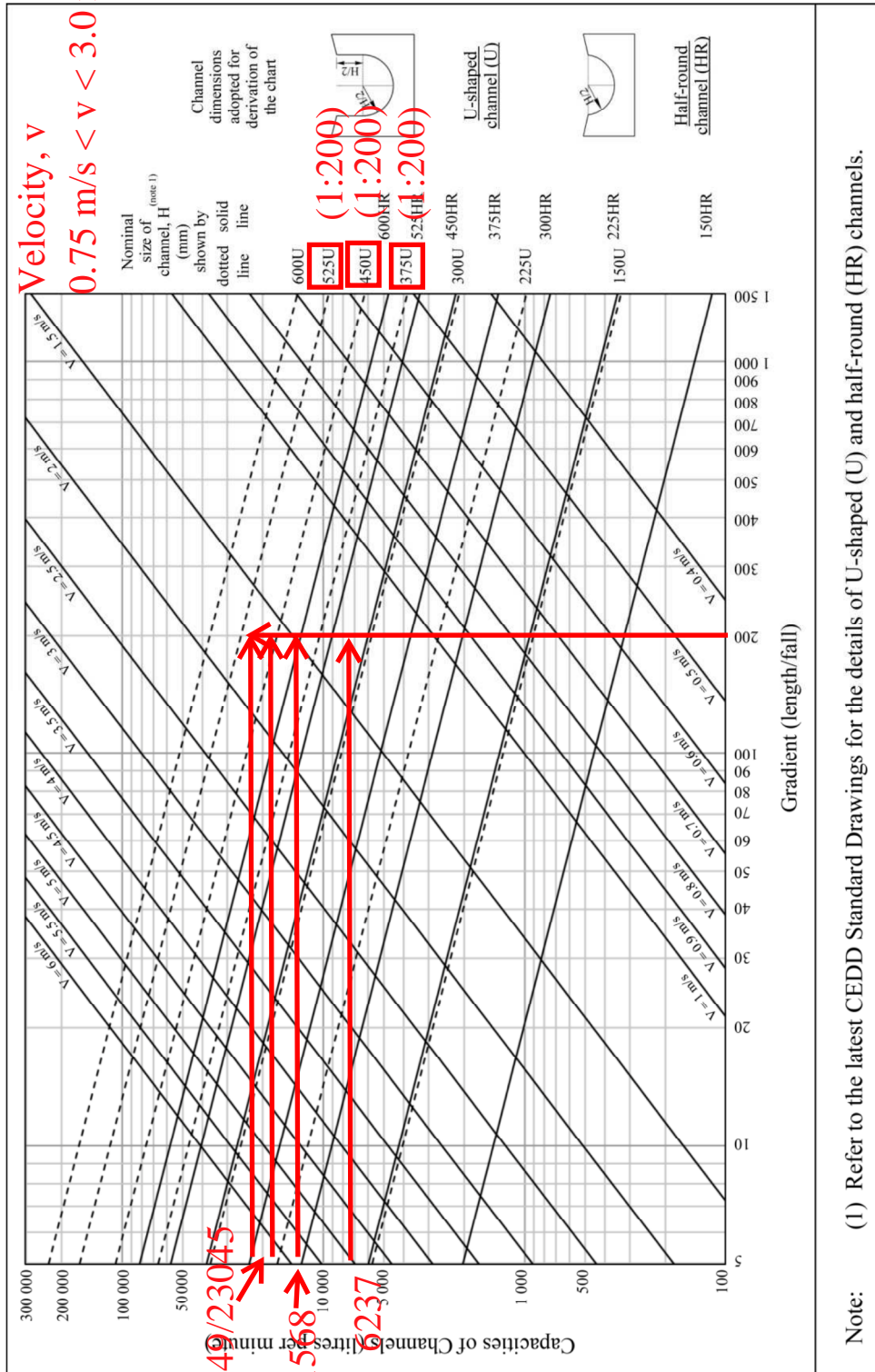

19705/1934/23045  
13112/11568  
2237

Check 525mm dia. Pipes by Colebrook-White Equation

$$V = -\sqrt{(8gDs)} \log\left(\frac{ks}{3.7D} + \frac{2.51v}{D\sqrt{(2gDs)}}\right)$$

where :

V	=		mean velocity (m/s)
g	=	9.81	m/s <sup>2</sup> gravitational acceleration (m/s <sup>2</sup> )
D	=	0.525	m internal pipe diameter (m)
ks	=	0.00006	m hydraulic pipeline roughness (m) (Table14, from DSD SDM 2018, concrete pipe)
v	=	1.14E-06	m <sup>2</sup> /s kinematic viscosity of fluid (m <sup>2</sup> /s)
s	=	0.01	hydraulic gradient (1: 100 )

Therefore, design V of pipe capacity = 2.77 m/s

Q= 0.8VA	(0.8 factor for sedimentation)
= 0.480	m <sup>3</sup> /s
= 28813	lit/min
> 19349	lit/min Ok

Check 600mm dia. Pipes by Colebrook-White Equation

$$V = -\sqrt{(8gDs)} \log\left(\frac{ks}{3.7D} + \frac{2.51v}{D\sqrt{(2gDs)}}\right)$$

where :

V	=		mean velocity (m/s)
g	=	9.81	m/s <sup>2</sup> gravitational acceleration (m/s <sup>2</sup> )
D	=	0.6	m internal pipe diameter (m)
ks	=	0.00006	m hydraulic pipeline roughness (m) (Table14, from DSD SDM 2018, concrete pipe)
v	=	1.14E-06	m <sup>2</sup> /s kinematic viscosity of fluid (m <sup>2</sup> /s)
s	=	0.008	hydraulic gradient (1: 125 )

Therefore, design V of pipe capacity = 2.68 m/s

Q= 0.8VA		(0.8 factor for sedimentation)
= 0.607	m <sup>3</sup> /s	
= 36409	lit/min	
> 34612	lit/min	Ok



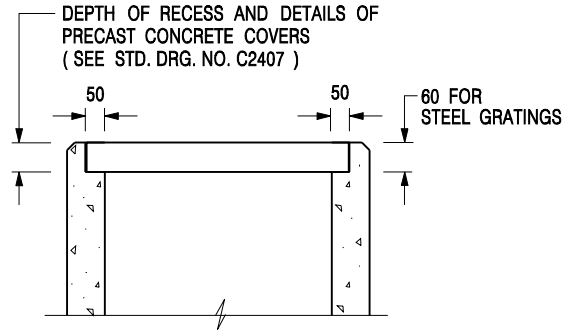

**ALTERNATIVE TOP SECTION  
FOR PRECAST CONCRETE COVERS / GRATINGS**

**NOTES:**

1. ALL DIMENSIONS ARE IN MILLIMETRES.
2. ALL CONCRETE SHALL BE GRADE 20 /20.
3. CONCRETE SURFACE FINISH SHALL BE CLASS U2 OR F2 AS APPROPRIATE.
4. FOR DETAILS OF JOINT, REFER TO STD. DRG. NO. C2413.
5. CONCRETE TO BE COLOURED AS SPECIFIED.
6. UNLESS REQUESTED BY THE MAINTENANCE PARTY AND AS DIRECTED BY THE ENGINEER, CATCHPIT WITH TRAP IS NORMALLY NOT PREFERRED DUE TO PONDING PROBLEM.
7. UPON THE REQUEST FROM MAINTENANCE PARTY, DRAIN PIPES AT CATCHPIT BASE CAN BE USED BUT THIS IS FOR CATCHPITS LOCATED AT SLOPE TOE ONLY AND AS DIRECTED BY THE ENGINEER.
8. FOR CATCHPITS CONSTRUCTED ON OR ADJACENT TO A FOOTPATH, STEEL GRATINGS ( SEE DETAIL 'A' ON STD. DRG. NO. C2405 /2 ) OR CONCRETE COVERS ( SEE STD. DRG. NO. C2407 ) SHALL BE PROVIDED AS DIRECTED BY THE ENGINEER.
9. IF INSTRUCTED BY THE ENGINEER, HANDRAILING ( SEE DETAIL 'J' ON STD. DRG. NO. C2405 /5; EXCEPT ON THE UPSLOPE SIDE ) IN LIEU OF STEEL GRATINGS OR CONCRETE COVERS CAN BE ACCEPTED AS AN ALTERNATIVE SAFETY MEASURE FOR CATCHPITS NOT ON A FOOTPATH NOR ADJACENT TO IT. TOP OF THE HANDRAILING SHALL BE 1 000 mm MIN. MEASURED FROM THE ADJACENT GROUND LEVEL.
10. MINIMUM INTERNAL CATCHPIT WIDTH SHALL BE 1 000 mm FOR CATCHPITS WITH A HEIGHT EXCEEDING 1 000 mm MEASURED FROM THE INVERT LEVEL TO THE ADJACENT GROUND LEVEL. AND, STEP IRONS ( SEE DSD STD. DRG. NO. DS1043 ) AT 300 c/c STAGGERED SHALL BE PROVIDED. THICKNESS OF CATCHPIT WALL FOR INSTALLATION OF STEP IRONS SHALL BE INCREASED TO 150 mm.
11. FOR RETROFITTING AN EXISTING CATCHPIT WITH STEEL GRATING, SEE DETAIL 'G' ON STD. DRG. NO. C2405 /4.
12. SUBJECT TO THE APPROVAL OF THE ENGINEER, OTHER MATERIALS CAN ALSO BE USED AS COVERS / GRATINGS.

A	MINOR AMENDMENT.	Original Signed	04.2016
-	FORMER DRG. NO. C2406J.	Original Signed	03.2015
<b>REF.</b>	<b>REVISION</b>	<b>SIGNATURE</b>	<b>DATE</b>

**CATCHPIT WITH TRAP  
(SHEET 2 OF 2)**

 <b>CIVIL ENGINEERING AND DEVELOPMENT DEPARTMENT</b>	
<b>SCALE</b> 1 : 20	<b>DRAWING NO.</b> C2406 /2A
<b>DATE</b> JAN 1991	

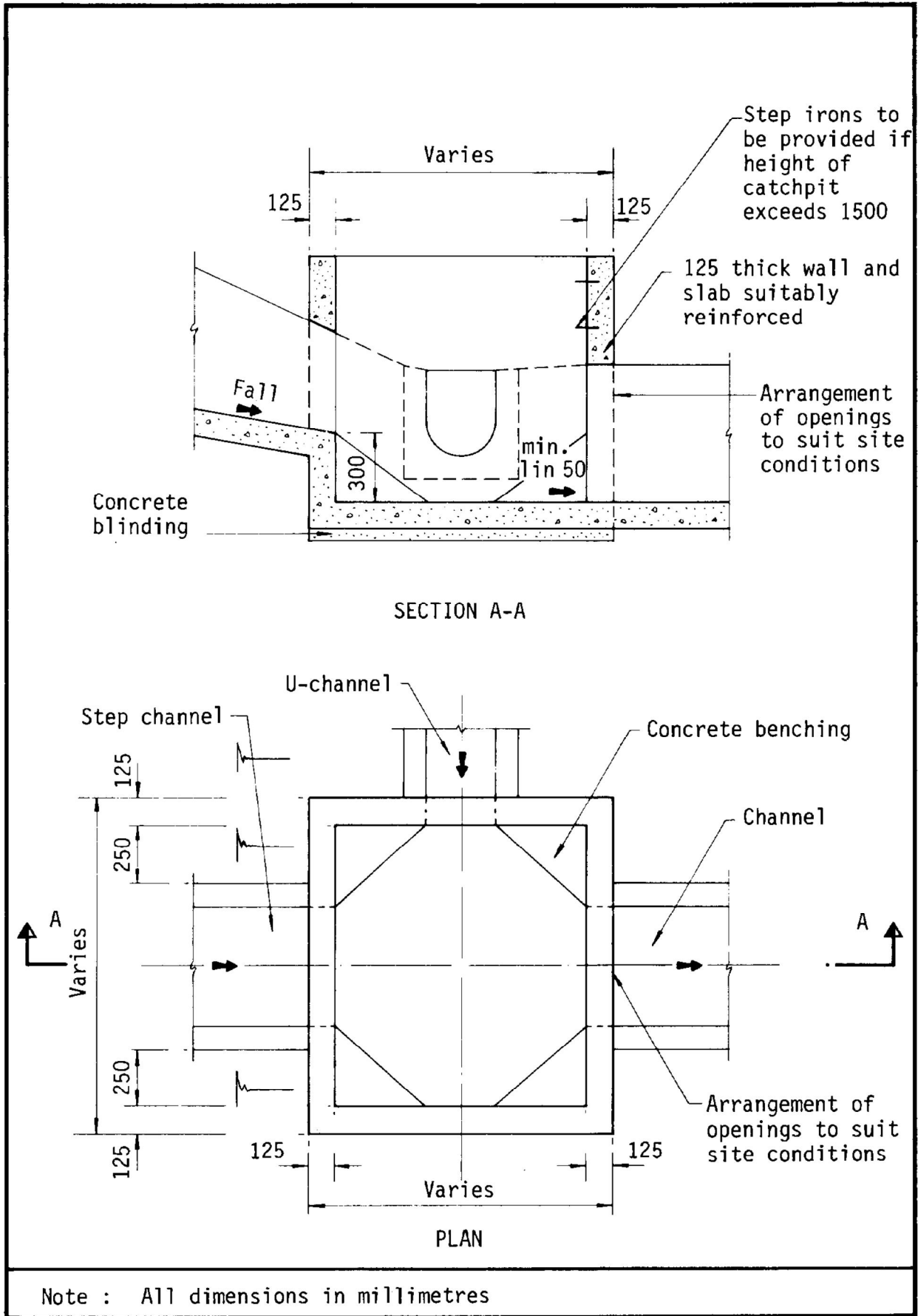
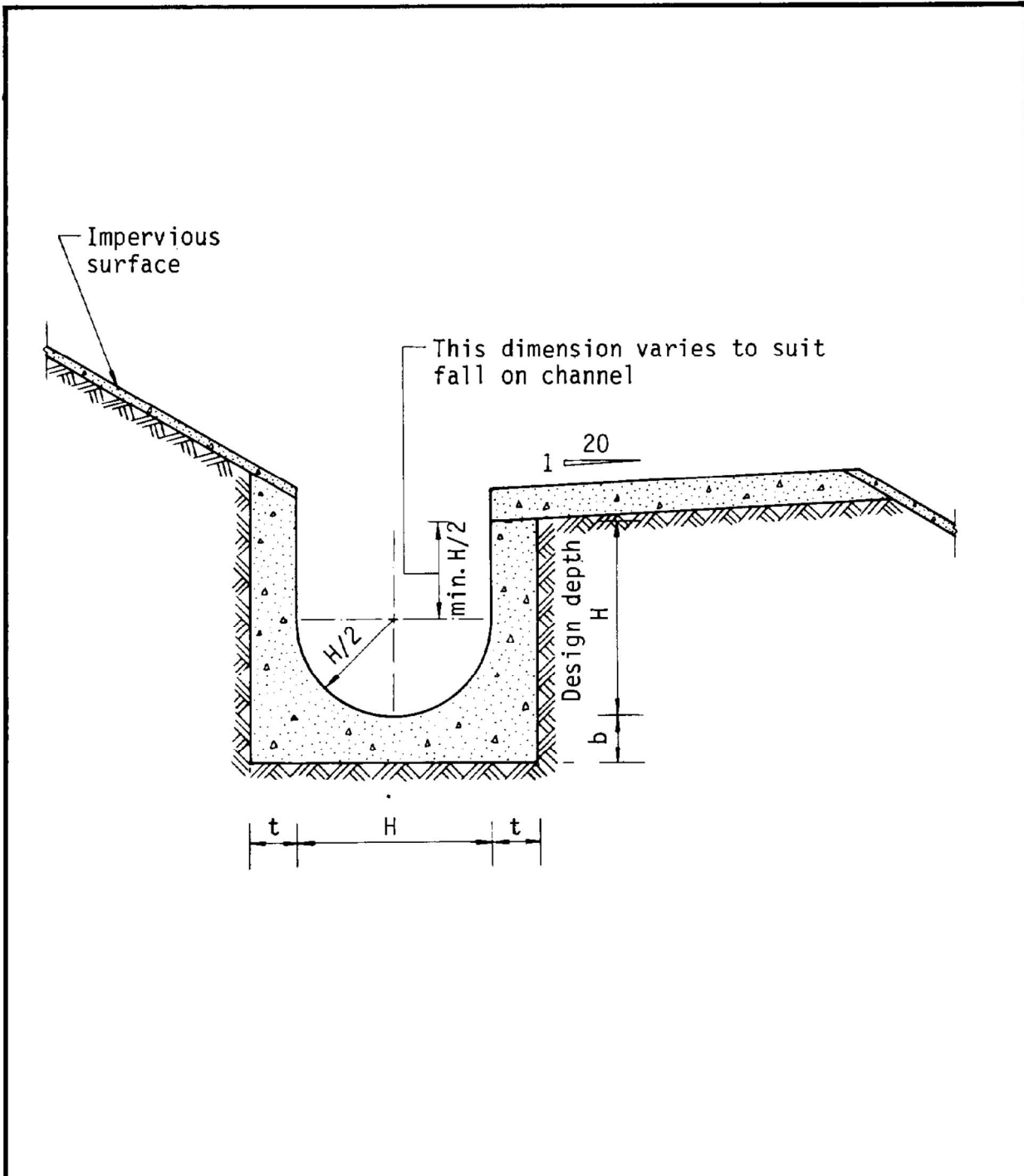

Figure 8.10 - Typical Details of Catchpits



Dimensions of U - channel

Nominal size of channel H (mm)	Thickness t (mm)	Thickness b (mm)
225 to 600	150	150
675 to 1200	175	225

Figure 8.11 - Typical U-channel Details

*S.16 Planning Application for Proposed Temporary Warehouse (Excluding Dangerous Goods Godown) with Ancillary Facilities and Associated Filling of Land for a Period of 3 Years in "Agriculture" Zone, Lots 1212 (Part), 1213, 1214, 1215, 1216, 1447 (Part), 1448 (Part), 1477 S.A (Part), 1478 RP (Part) in D.D. 106 and Adjoining Government Land, Kam Tin, Yuen Long, New Territories*

*Planning Statement*

---

## **Appendix E**

### **Tree Survey**

**Tree Survey Report  
of  
VARIOUS LOTS IN D.D. 106 AND  
ADJOINING GOVERNMENT LAND, KAM  
TIN, YUEN LONG, NEW TERRITORIES**

**Prepared by:**

**Wong Wai Chun  
AA- Technician Member**



**Report Date: 27<sup>th</sup> April 2026**

## 1) INTRODUCTION

We are commissioned to prepare a tree survey report to record the health condition of the existing trees at the proposed survey area at Various Lots in D.D. 106, Adjoining Government Land, Kam Tin, Yuen Long, New Territories.

## 2) DATE OF INSPECTION

The inspections were conducted on 26<sup>th</sup> April 2026.

## 3) SITE ADDRESS AND LOCATIONS OF TREES

The inspected trees were located at the designated working area at Various Lots in D.D. 106, Adjoining Government Land, Kam Tin, Yuen Long, New Territories. Please find the Tree Location Plan in Appendix C.

## 4) METHODOLOGY OF TREE INSPECTION

The tree inspection basically adopted the Visual Tree Assessment (VTA) techniques. All vegetation present with a trunk diameter larger than 95mm when measured at a point 1300mm above ground level was considered as a 'tree'. These have been surveyed and identified with the information recorded on the following pages. The tree assessment is undertaken in accordance with the 'Development Bureau Technical Circular (Works) No. 4/2020 Tree preservation' and 'Guidelines for Tree Risk Assessment and Management Arrangement' (4/2020 9<sup>th</sup> Edition) from the Greening, Landscape and Tree Management Section of Development Bureau.

- (A) Tree ID No.: The individual trees have been tagged on site using weatherproof labels with the abbreviated number T- which correspond with those in survey plans.
- (B) Species: The botanical and Chinese names of the trees have been used

for ease of reference. The botanical name takes precedence wherever there is any ambiguity.

(C) Tree Size:

- (1) Overall height : Height measured in meters from ground level to the top of the tallest branch.
- (2) Trunk Diameter : Diameter of the main trunk measured in millimeters at 1.3 m high above ground level.
- (3) Crown Spread : Average diameter of the foliage canopy.

(D) Form:

- (1) Good – Well-balanced crown and straight strong trunk(s);
- (2) Fair – Slightly unbalanced crown and non-straight trunk(s);
- (3) Poor – Misshapen or awkwardly forked trunk and/or unbalanced crown.

(G) Health: The health condition of each tree shall be evaluated according to the following criteria (Webb 1991):

- (1) Good - Trees of good form, moderate to large size and in good health are classified as *good*;
- (2) Fair - Trees of reasonable form, with few or no visible defects or health problems are classified as being *fair*;
- (3) Poor - Trees that are of poor form, badly damaged or clearly suffering from decay, dying back or the effects of very heavy vine growth are classified as *poor*.

(H) Amenity Value: The Amenity Value rating is the intrinsic value of each tree derived from the combination of the tree's health and form, cultural significance and the economic value contributed to the property owner/community. The following ratings are developed in conjunction with 'Development Bureau Technical Circular (Works) No.4/2020 Tree preservation'.

- (1) High - Trees included in the Register of Old and Valuable Trees (OVT) under the Works Branch of Development Bureau OR similar trees potentially registrable under the same criteria OR trees of particular value as specified under lease or property owner's consent
- (2) Moderate - Non-invasive, healthy trees with fair health and form which contribute to the local greenery and have a fair chance of surviving and growing if optimal conditions are favored
- (3) Low - Trees with poor health and form or with declining conditions OR invasive species which can potentially threaten other native species OR hazardous trees causing public safety concerns

Photographic record in JPEG format showing the overall view from the trunk base up to the canopy of each surveyed tree shall be attached at the end of the tree survey report.

All surveyed trees shall be marked on Tree Survey Plans with their tree ID.

The biographical information for the trees is as per attached Tree Assessment Schedule.

Please refer to **Appendix A**.

The photographic record of individual trees are referred to **Appendix B**.

The location plan of surveyed trees is referred to **Appendix C**.

## 5) FINDINGS

There was total 5 trees observed at the designated working area at Various Lots in D.D. 106, Adjoining Government Land, Kam Tin, Yuen Long, New Territories. No Old and Valuable Tree (OVT) or rare tree species could be found. No tree failure was observed. The dominant species were *Macaranga tanarius* (L.) Müll. Arg. var. *tomentosa* (Blume) Müll. Arg. and *Ficus hispida*.

## Appendix A

**Tree survey schedule**

Location: VARIOUS LOTS IN D.D. 106 AND ADJOINING GOVERNMENT LAND, KAM TIN, YUEN LONG, NEW TERRITORIES

Date: 26-Apr-26

Tree No.	Species:	Size			Status		Amenity Value	Observable Defects / Damages of Trees	Remarks:
		Overall Height(m)	Diameter (mm)	Average Crown Spread (m)	Condition (Good, Fair, Poor, Dead)	Form (Good, Fair, Poor)			
T1	<i>Macaranga tanarius</i> (L.) Müll. Arg. var. <i>tomentosa</i> (Blume) Müll. Arg.	5	114	4	F	F	Co-dominant branches, Climber, Restricted root		
T2	<i>Ficus hispida</i>	6	160	7	F	F	Co-dominant branches, Climber, Restricted root		
T3	<i>Macaranga tanarius</i> (L.) Müll. Arg. var. <i>tomentosa</i> (Blume) Müll. Arg.	6	267+250+110	8	F	F	Co-dominant trunks, Climber, Included bark, Wound, Abnormal bark crack		
T4	<i>Macaranga tanarius</i> (L.) Müll. Arg. var. <i>tomentosa</i> (Blume) Müll. Arg.	8	320	10	F	F	Co-dominant branches, Climber		
T5	<i>Ficus hispida</i>	6	150	5	F	F	Co-dominant branches, Climber		

## Appendix B

# Photographic record of trees



T1 (1)



T1 (2)



T1 (3)



T1 (4)

# Photographic record of trees



T2 (1)



T2 (2)



T2 (3)

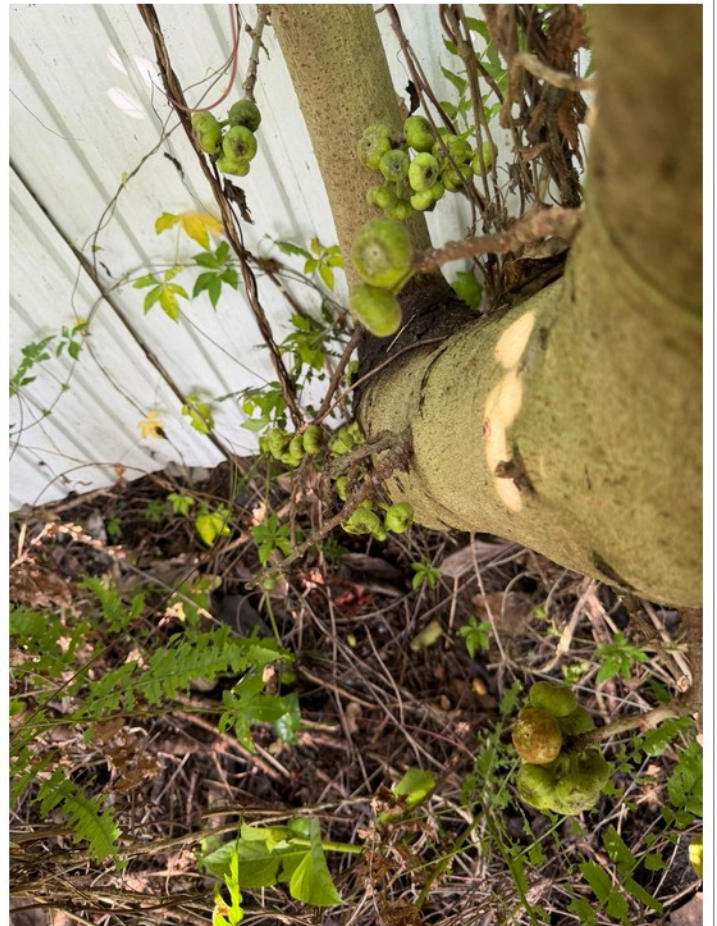

T2 (4)

# Photographic record of trees



T3 (1)



T3 (2)



T3 (3)



T3 (4)

## Photographic record of trees



T4



T5

## Appendix C



*S.16 Planning Application for Proposed Temporary Warehouse (Excluding Dangerous Goods Godown) with Ancillary Facilities and Associated Filling of Land for a Period of 3 Years in "Agriculture" Zone, Lots 1212 (Part), 1213, 1214, 1215, 1216, 1447 (Part), 1448 (Part), 1477 S.A (Part), 1478 RP (Part) in D.D. 106 and Adjoining Government Land, Kam Tin, Yuen Long, New Territories*

*Planning Statement*

---

## **Appendix F**

### **Landscape Proposal**

